

GOVERNMENT OF UTTARAKHAND

**Office of Superintending Engineer,
Research Circle**

Irrigation Research Institute Roorkee-247667

E-mail: uttarkhandwrd@gmail.com, Website: www.iriroorkee.res.in

e-Tender Notice No. : 11/SE (R)/ NHP/ e-Tender/ 2020-21, Dated 07.01.2021

Superintending Engineer, Research Circle, Irrigation Research Institute, Roorkee on behalf of "Governor of Uttarakhand" invites item wise rates for the "Drilling and installation of 66 nos. groundwater monitoring wells and construction of 66 nos. Protection works for DWLR telemetry system to monitor groundwater level and quality under National Hydrology Project (NHP) in Uttarakhand State" through e-tenders in "Two Bid System" as given below.

S. No.	Name of work	Earnest Money (Rs.)	Cost of tender form (Rs.)	Validity of Tender	Period of completion
1	2	3	4	5	6
1	Drilling and installation of 66 nos. groundwater monitoring wells and construction of 66 nos. Protection works for DWLR telemetry system to monitor groundwater level and quality under National Hydrology Project (NHP)	5.40 Lac	5,000.00+ GST @ 18%	120 Days	09 months

Key Dates

1	Date of calling	07.01.2021	-
2	Date of online publication	08.01.2021	03.00 PM
3	Documents downloads start date	08.01.2021	05.00 PM
4	Pre-bid meeting date	15.01.2021	11.30 AM
5	Bid submission start date	29.01.2021	03.30 PM
6	Bid submission end date	09.02.2021	03.00 PM
7	Physical Submission of bid security and cost of bidding document	09.02.2021	03.00 PM
8	Date of opening of Technical bid	09.02.2021	03.30 PM
9	Date of opening of financial bid	To be declared later	

For further details please log on to www.uktenders.gov.in

Superintending Engineer
Research Circle

Irrigation Research Institute, Roorkee

Signature Not Verified

Digitally signed by Shankar Kumar Saha
Date: 2021.01.07 18:46:12 IST
Location: Uttarakhand-UT

Letter of Bid – Financial Part

The Bidder must prepare the Letter of Bid on stationery with its letterhead clearly showing the Bidder's complete name and address.

Note: All italicized text is for use in preparing these forms and shall be deleted from the final products.

Date: _____

Invitation for Bid No.: _____

To:

*The Superintending Engineer,
Research Circle.
Irrigation Research Institute, Roorkee- 247667*

We, the undersigned, hereby submit the second part of our Bid, the Bid Price and Bill of Quantities. This accompanies the Letter of Technical Part:

In submitting our Bid, we make the following declarations:

- (a) Our bid shall be valid for a period of _____ *[insert validity period as specified in ITB 18.1.]* days from the date fixed for the bid submission deadline in accordance with the Bidding Documents, and it shall remain binding upon us and may be accepted at any time before the expiration of that period;
- (b) The total price of our Bid, excluding any discounts offered in item (c) below is:
 - In case of only one lot, total price of the Bid *[insert the total price of the bid in words and figures];*
 - In case of multiple lots, total price of each lot *[insert the total price of each lot in words and figures];*
 - In case of multiple lots, total price of all lots (sum of all lots) *[insert the total price of all lots in words and figures];*
- (c) The discounts offered and the methodology for their application are:
 - (i) The discounts offered are: *[Specify in detail each discount offered.]*
 - (ii) The exact method of calculations to determine the net price after application of discounts is shown below: *[Specify in detail the method that shall be used to apply the discounts];*

(d) We have paid, or will pay the following commissions, gratuities, or fees with respect to the bidding process or execution of the Contract:¹⁵

Name of Recipient	Address	Reason	Amount
.....
.....

Name of the Bidder* *[insert complete name of person signing the Bid]*

Name of the person duly authorized to sign the Bid on behalf of the Bidder** *[insert complete name of person duly authorized to sign the Bid]*

Title of the person signing the Bid *[insert complete title of the person signing the Bid]*

Signature of the person named above *[insert signature of person whose name and capacity are shown above]*

Date signed *[insert date of signing]* day of *[insert month]*, *[insert year]*

*: In the case of the Bid submitted by joint venture specify the name of the Joint Venture as Bidder

** : Person signing the Bid shall have the power of attorney given by the Bidder to be attached with the Bid Schedules.

.....
.....

¹⁵*If none has been paid or is to be paid, indicate "none".*

Appendix to Financial Part

Bill of Quantities

Appendix to Financial Part

Bill of Quantities

S. No.	Item of Work	Qty.	Unit	BASIC RATE In Figures To be entered by the Bidder in INR	GST Amount in INR	Any Other Taxes In INR	TOTAL AMOUNT Without Taxes. In INR	TOTAL AMOUNT With Taxes. In INR	TOTAL AMOUNT In Words
1	Drilling and installation of 66 nos. groundwater monitoring wells								
1.01	Site clearance at the beginning of drilling works and site finishing after completion of all works.	66.00	Job						
1.02	Drilling of borehole required as per site minimum bore size 300 mm after reaming including water arrangement for drilling, back ashing, collecting of samples from different strata, preparing and submitting strata chart etc. In soil Complete	800.00	Mtr						
1.03	Drilling of borehole required as per site minimum bore size 250 mm after reaming including water arrangement for drilling, back ashing, collecting of samples from different strata, preparing and submitting strata chart etc. In Boulder and Rock Complete	2178.00	Mtr						
1.04	Supply of 110mm dia UPVC Plain pipe	251.00	Mtr						
1.05	Supply of 110mm dia UPVC Filter pipe with cap and mesh cloth M.L. T&P etc. all complete.	73.00	Mtr						
1.06	Supply of 100mm dia MS ERW fincut 5.40 mm thick Plain pipe with socket	1562.00	Mtr						
1.07	Supply of 100 mm dia MS ERW fincut 5.40 mm thick slotted pipe with socket	1102.00	Mtr						
1.08	Supply of 100 mm dia, 5.40 mm thick tubewell cap.	60.00	No						
1.09	Supply of 100 mm dia M.S.D.I housing clamp	66.00	No						

	complete.								
1.10	Supply and fixing of 100 mm dia Bail plug with nut & U- bolt as required.	60.00	No						
1.11	Supply of Pea gravel	251.00	Cum						
1.12	Lowering of 110 mm dia Upvc pipe and 100 mm MSERW housing pipe (Plain & Slotted pipe) as required.	3000.00	Mtr.						
1.13	Fixing of 100 mm dia, 5.40 mm thick tubewell cap.	60.00	Job						
1.14	Development of tubewell by 250 PSI Air compressor unit to the satisfaction of Engineer in charge to give a sand free discharge & Proper packing of pea gravel.	2508.00	Hrs						
2	Supply, Fixing, Installation, Fabrication & Painting of protection box and Sign Board								
2.01	Construction of Protection box of size 65 cm x 65 cm x 45 cm with 3.15 mm thick Galvanized steel sheet including Fabrication, painting with two more layers of Primer and non-corrosive all weather branded paint including locking system, 7 lever brass lock with three keys, including costs of all materials labour, wastage & additional steel, T&P etc. complete	66.00	Nos.						
2.02	Construction of 66 nos. of Sign Board of size 100 cm x 100 cm with 3.15 mm thick Galvanized steel sheet including Fabrication, painting with two more layers of Primer and non-corrosive all weather branded paint, of display board including costs of all materials labour, wastage & additional steel, T&P etc. complete	66.00	Nos.						
2.03	Writing of matter on display board with dark brightening all weather paint as per direction of EIC including costs of all materials, labour, T&P	66.00	Nos.						

	etc. complete								
2.04	Dowel tubes (Corrugated GI pipes 50 mm dia) for sign board including Fabrication, painting with two more layers of Primer and non-corrosive all weather branded paint of GI pipes, fixing with display board & foundation including costs of all materials labour, wastage & additional steel, T&P etc. complete @50% of cost of GI Pipes	66.00	Nos.						
3	Civil Work for Protection Block & Sign Board								
3.01	Providing and laying in position cement concrete of specified grade excluding the cost of centering and shuttering - All work up to plinth level 1:2:4 (1 cement : 2 coarse sand (zone-III) : 4 graded stone aggregate 20 mm nominal size)	43.27	Cum						
3.02	Centering and shuttering including strutting, propping etc. and removal of form for all heights :Foundations, footings, bases of columns, etc. for mass concrete	308.25	Sqm						
3.03	Providing and laying in position cement concrete of specified grade excluding the cost of centering and shuttering - All work up to plinth level. 1:4:8 (1 Cement : 4 coarse sand (zone-III) : 8 graded stone aggregate 40 mm nominal size).	7.53	Cum						
3.04	Earth work in excavation by mechanical means (Hydraulic excavator) / manual means in foundation trenches or drains (not exceeding 1.5 m in width or 10 sqm on plan), including dressing of sides and ramming of bottoms, lift upto 1.5 m, including getting out the excavated soil and disposal of surplus excavated soil as directed, within a lead of 50 m. For all kind of soils.	16.00	Cum						
3.05	Excavation work by mechanical means (Hydraulic excavator)/ manual means in	15.51	Cum						

	foundation trenches or drains (not exceeding 1.5m in width or 10 sqm on plan), including dressing of sides and ramming of bottoms, lift upto 1.5 m, including getting out the excavated soil and disposal of surplus excavated soils as directed, within a lead of 50 m in ordinary rock								
3.06	Providing and laying in position cement concrete of specified grade excluding the cost of centering and shuttering- all work upto plinth level 1:1.5:3 (1 cement : 1.5 coarse sand (zone-III): 3 graded stone aggregates 20 mm nominal size)	3.56	Cum						
3.07	Steel reinforcement for R.C.C. work including straightening, cutting, bending, placing in position and binding all complete upto plinth level. Thermo-Mechanically Treated bars of grade Fe-500D or more.	4890.00	Kg						
	Total Bid Price (in figures)								
	Total Bid Price (in figures)								

Note:

1. *Item for which no rate or price has been entered in will not be paid for by the Employer when executed and shall be deemed covered by the other rates and prices in the Bill of Quantities (refer: ITB Clause 14.2 and GCC Clause 41.3)*
2. *Unit rates and prices shall be quoted by the bidder in Indian Rupees [ITB Clause 14.1 and ITB Clause 15.1]*
3. *Where there is a discrepancy between the unit rate and the line item total resulting from multiplying the unit rate by quantity, the unit rate quoted shall govern as explained in ITB Clause 36.[Note: delete this point if the e-procurement system automatically calculates the total from the unit rate and quantity]*

4. *Where there is a discrepancy between the rate in figures and words, the rates in words will govern as explained in ITB Clause 36. [Note: delete this point if the e-procurement system automatically populates the amount in words from the amount in figures]*

NATIONAL COMPETITIVE BIDDING FOR

Drilling and installation of 66 nos. groundwater monitoring wells and construction of 66 nos. Protection works for DWLR telemetry system to monitor groundwater level and quality under National Hydrology Project (NHP) in Uttarakhand State.

(Two-Envelope Bidding Process with e-Procurement)

INVITATION FOR BIDS (IFB)

E-Procurement Notice

Date : 09.04.2021

IBRD Loan No. : 8725IN

IFB No. : 11/SE(R)/NHP/e-Tender/2020-21, Dated 09.04.2021

1. This Invitation for Bid follows the General Procurement Notice for this Project that appeared in Development Business on 21/09/2016
2. The Government of India has received financing from World Bank towards the cost of National Hydrology project and it is intended that part of the proceeds will be applied to eligible payments under the contract for “Drilling and installation of 66 nos. groundwater monitoring wells and construction of 66 nos. Protection works for DWLR telemetry system to monitor groundwater level and quality under National Hydrology Project (NHP)” in Uttarakhand State.
3. The Superintending Engineer (Research Circle), Irrigation Research Institute, Roorkee now invites online bids from eligible bidders for “Drilling and installation of 66 nos. groundwater monitoring wells and construction of 66 nos. Protection works for DWLR telemetry system to monitor groundwater level and quality under National Hydrology Project (NHP)” in Uttarakhand State.
4. Bidders from India should, however, be registered with the Government of India or other State Governments/Government of India, or State/Central Government Undertakings. Bidders from India, who are not registered as above, on the date of bidding, can also participate provided they get themselves registered by the time of contract signing, if they become successful bidders. **Bidders are advised to note the clauses on eligibility (Section I Clause 4) and minimum qualification criteria (Section III – Evaluation and Qualification Criteria), to qualify for the award of the contract.** In addition, please refer to paragraphs 1.6 and 1.7 of the World Bank’s Guidelines setting forth the World Bank’s policy on conflict of interest.
5. Bidding will be conducted through the National Competitive Bidding (NCB) procedures agreed with World Bank. The bidding is open to all eligible bidders as defined in the Bank’s Procurement Guidelines. In addition, please refer to paragraphs 1.6 and 1.7 of the Guidelines setting forth the World Bank’s policy on conflict of interest.
6. Bidding documents are available online on Government e-procurement website, <https://uktenders.gov.in> for a non-refundable fee as indicated below, in the form of Demand Draft on any Scheduled/Nationalized bank payable at Roorkee in favour of “Executive Engineer, Design Division, IDO, Roorkee” (Demand Draft to be submitted subsequently as per the procedure described in paragraph 7 below). Bidders will be required to register in the website, which is free of cost. The bidder would be responsible for ensuring that any addenda available on the website is also downloaded and incorporated.

- (a) Price of bidding document(non-refundable) : 5000 + GST @18%
 - (b) Date of commencement of sale of bidding document : 12.04.2021 6.00 PM
 - (c) Date of Pre-bid meeting : 19.04.2021 1.30 PM
 - (d) Last date and time for receipt of bids : 12.05.2021 3:00 PM
 - (e) Time and date of opening of bids-technical part : 12.05.2021 3:30 PM
7. For submission of the bids, the bidder is required to have Digital Signature Certificate (DSC) from one of the authorized Certifying Authorities, authorised by Government of India for issuing DSC.
 8. All bids must be accompanied by a Bid Security of the amount specified in the bidding document, drawn in favour of “Executive Engineer, Design Division, IDO, Roorkee”. The Bid security will have to be in any one of the forms as specified in the bidding document and shall have to be valid for 120 days beyond the validity of the bid.
 9. Bids must be submitted online on <https://uktenders.gov.in> (website) on or before the date and time for receipt of bids, and the ‘Technical Part’ of bids will be opened on the specified time and date for opening of bids, as given above. The financial bid of technically qualified bidder will be opened later. The date of opening of financial bid will be declared later. Any bid or modifications to bid (including discount) received outside e-procurement system will not be considered. If the office happens to be closed on the date of opening of the bids as specified, the bids will be opened on the next working day at the same time. The electronic bidding system would not allow any late submission of bids.
 10. The bidders are required to submit (a) original demand drafts towards the cost of bid document (b) original demand drafts towards the GST amount (c) original bid security in approved form; and (d) original affidavit regarding correctness of information furnished with bid document before the opening of the technical part of the Bid given above; (e) original affidavit regarding validity of rates for 120 days from the date of opening of Financial bid, either by registered post/speed post/courier or by hand, failing which the bids will be declared non-responsive. Due to valid unavoidable circumstances, if bidder(s) fails to submit the hard copies of aforesaid original documents before the opening of technical bid, the bidder must submit these original documents within the stipulated time as intimated by the Purchaser. If bidder(s) will not provide these original documents within prescribed time as given by the Purchaser, his/their bid(s) will be declared as non-responsive and in such situation Purchaser may take any action against such bidder(s).
 11. A pre-bid meeting will be held on 19.04.2021 at 1.30 PM through video conference to clarify the issues and to answer questions on any matter that may be raised at the stage as stated in ITB clause 7.1 of “Instructions to Bidders” of the bidding documents. All prospective bidder(s) are requested to submit his query, if any, through email before 19.04.2021.
 12. Other details can be seen in the bidding document. The Purchaser shall not be held liable for any delays due to system failure beyond its control. Even though the system will attempt to notify the bidders of any bid updates, the Purchaser shall not be liable for any information not received by the bidder. It is the bidder’s responsibility to verify the website for the latest information related to this bid.

TABLE

Package no.	Brief Description of the work	Approximate value of work including all taxes (Rs. In Lakh)	Bid Security (Rs. In Lakh)	Cost of documents	Completion period
11/SE (R)/NHP/e-Tender/2020-21, Dated.07.01.2021	DRILLING AND INSTALLATION OF 66 NOS GROUNDWATER MONITORING WELLS AND CONSTRUCTION OF 66 NOS. PROTECTION WORKS FOR DWLR TELEMETRY IN UTTARAKHAND BY DTH METHOD.	270.06	5.40	5,000.00+ GST @ 18%	09 months

Superintending Engineer (Research Circle),
 Irrigation Research Institute
 SPMU, NHP
 Roorkee, District – Haridwar, Uttarakhand

PART 1 – BIDDING PROCEDURE

SECTION I - INSTRUCTIONS TO BIDDERS [ITB]

Table of Clauses

A. General.....	9
1. Scope of Bid.....	9
2. Source of Funds	9
3. Corrupt and Fraudulent Practices.....	9
4. Eligible Bidders	10
5. Eligible Materials, Equipment and Services	13
B. Contents of Bidding Document.....	13
6. Sections of Bidding Document	13
7. Clarification of Bidding Document, Site Visit, Pre-Bid Meeting.....	13
8. Amendment of Bidding Document.....	15
C. Preparation of Bids	15
9. Cost of Bidding	15
10. Language of Bid.....	15
11. Documents Comprising the Bid.....	15
12. Process of Bid Submission.....	16
13. Alternative Bids	17
14. Bid Prices and Discounts	17
15. Currencies of Bid and Payment	18
16. Documents Comprising the Technical Proposal.....	18
17. Documents Establishing the Qualifications of the Bidder.....	19
18. Period of Validity of Bids	19
19. Bid Security	19
20. Format and Signing of Bid.....	20
D. Online Submission and Opening of Bids	21
21. Preparation of Bids	21
22. Deadline for Submission of Bids	22
23. Late Bids	22
24. Withdrawal, Substitution, and Modification of Bids.....	22
25. Public Opening of Technical Parts of Bids.....	22
F. Evaluation of Bids – General Provisions	23
26. Confidentiality	23
27. Clarification of Bids.....	23
28. Deviations, Reservations, and Omissions	23
29. Nonconformities, Errors, and Omissions.....	24
30. Evaluation of Technical Parts	24
31. Determination of Responsiveness.....	24
32. Qualification of the Bidder	25
33. Subcontractors.....	25
34. Public Opening of Financial Parts	25
35. Evaluation of Financial Parts	27
36. Correction of Arithmetical Errors	27

37	Conversion to Single Currency	27
38	Margin of Preference	27
39	Comparison of Financial Parts	27
40	Unbalanced or Front Loaded Bids	27
41	Employer’s Right to Accept Any Bid, and to Reject Any or All Bids	28
J. Award of Contract		28
42	Award Criteria	28
43	Notification of Award	28
44	Signing of Contract, Publication of award and Recourse to unsuccessful Bidders	28
45	Performance Security	29
46	Adjudicator or Dispute Review Expert.....	29

Section I - Instructions to Bidders

A. General

1. **Scope of Bid**
 - 1.1 The Employer, as **indicated in the BDS**, issues this Bidding Document for the procurement of the Works as specified in Section VII (Work's Requirements) & Invitation for Bids (IFB). The name, identification, and number of contracts of this bidding are **specified in the BDS**.
 - 1.2 Throughout this Bidding Document:
 - (a) the term "in writing" means communicated in written form and delivered against receipt;
 - (b) except where the context requires otherwise, words indicating the singular also include the plural and words indicating the plural also include the singular; and
 - (c) "day" means calendar day.
2. **Source of Funds**
 - 2.1 The Government of India or the Recipient (hereinafter called "Borrower") **specified in the BDS** has received/applied for financing (hereinafter called "funds") from the International Bank for Reconstruction and Development or the International Development Association (hereinafter called "the Bank") in an amount **specified in the BDS**, towards the cost of the project **specified in the BDS**. The Borrower intends to apply a portion of the funds to eligible payments under the contract(s) for which this Bidding Document is issued.
 - 2.2 Payment by the Bank will be made only at the request of the Borrower and upon approval by the Bank, and will be subject, in all respects, to the terms and conditions of the Loan (or other financing) Agreement. The Loan (or other financing) Agreement prohibits a withdrawal from the Loan (or other financing) account for the purpose of any payment to persons or entities, or for any import of goods, if such payment or import, is prohibited by a decision of the United Nations Security Council taken under Chapter VII of the Charter of the United Nations. No party other than the Borrower shall derive any rights from the Loan (or other financing) Agreement or have any claim to the proceeds of the Loan (or other financing).
3. **Corrupt and Fraudulent Practices**
 - 3.1 The Bank requires compliance with its policy in regard to corrupt and fraudulent practices as set forth in Section VI.
 - 3.2 In further pursuance of this policy, Bidders shall permit and shall cause its agents (whether declared or not), sub-contractors, sub-consultants, service providers, or suppliers and any personnel thereof, to permit the Bank to inspect all accounts, records and other documents relating to any prequalification process, bid submission, and contract performance (in the case of award), and to have them audited by auditors appointed by

the Bank.

- 4. Eligible Bidders**
- 4.1.1 A Bidder may be a firm that is a private entity, or a government-owned entity—subject to ITB 4.5—or any combination of such entities in the form of a joint venture (JV), under an existing agreement, or with the intent to constitute a legally-enforceable joint venture, unless otherwise **specified in the BDS**.
- 4.1.2 Bids submitted by a joint venture of two or more firms as members when permitted as per BDS ITB Clause 4.1.1 shall comply with the following requirements:
- [a] the bid shall include all the information listed in Bidders Qualification Forms for all the Members. The maximum number of members in the Joint Venture shall be as **specified in the BDS**;
 - [b] the bid and, in case of a successful bid, the Agreement, shall be signed so as to be legally binding on all members;
 - [c] one of the members shall be nominated as being in charge, and this authorization shall be evidenced by submitting a power of attorney signed by legally authorized signatories of all the members;
 - [d] the member in charge shall be authorized to incur liabilities and receive instructions for and on behalf of any and all members of the joint venture and the entire execution of the contract, including payment, shall be done exclusively with the member in charge;
 - [e] all members of the joint venture shall be liable jointly and severally for the execution of the contract in accordance with the contract terms, and a statement to this effect shall be included in the authorization mentioned under (c) above, as well as in the bid and in the Agreement [*in case of a successful bid*];
 - [f] The joint venture agreement should indicate precisely the role of all members of JV in respect of planning, design, construction equipment, key personnel, work execution, and financing of the project. All members of JV should have active participation in the execution during the currency of the contract. This should not be varied/modified subsequently without prior approval of the Employer;
 - [g] The joint venture agreement should be registered in place **specified in BDS** so as to be legally valid and binding on members; and
 - [h] a copy of the Joint Venture Agreement entered into by the members shall be submitted with the bid. Alternatively, a Letter of Intent to execute a Joint Venture Agreement in the event of a successful bid shall be signed by all members and submitted with the bid, together with a copy

of the proposed Agreement.

- 4.2 A Bidder shall not have a conflict of interest. All Bidders found to have a conflict of interest shall be disqualified. A Bidder may be considered to have a conflict of interest for the purpose of this bidding process, if the Bidder:
- (a) directly or indirectly controls, is controlled by or is under common control with another Bidder; or
 - (b) receives or has received any direct or indirect subsidy from another Bidder; or
 - (c) has the same legal representative as another Bidder; or
 - (d) has a relationship with another Bidder, directly or through common third parties, that puts it in a position to influence the bid of another Bidder, or influence the decisions of the Employer regarding this bidding process; or
 - (e) participates in more than one bid in this bidding process. Participation by a Bidder in more than one Bid will result in the disqualification of all Bids in which such Bidder is involved. However, this does not limit the inclusion of the same subcontractor in more than one bid; or
 - (f) any of its affiliates participated as a consultant in the preparation of the design or technical specifications of the works that are the subject of the bid; or
 - (g) any of its affiliates has been hired (or is proposed to be hired) by the Employer or Borrower as Project Manager (Engineer) for the Contract implementation; or
 - (h) would be providing goods, works, or non-consulting services resulting from or directly related to consulting services for the preparation or implementation of the project specified in the BDS ITB 2.1 that it provided or were provided by any affiliate that directly or indirectly controls, is controlled by, or is under common control with that firm; or
 - (i) has a close business or family relationship with a professional staff of the Borrower (or of the project implementing agency, or of a recipient of a part of the loan) who: (i) are directly or indirectly involved in the preparation of the bidding documents or specifications of the contract, and/or the bid evaluation process of such contract; or (ii) would be involved in the implementation or supervision of such contract unless the conflict stemming from such relationship has been resolved in a manner acceptable to the Bank throughout the procurement process and execution of the contract.
- 4.3 A Bidder may have the nationality of any country, subject to the restrictions pursuant to ITB 4.7. A Bidder shall be deemed to have the nationality of a country if the Bidder is constituted, incorporated or registered in and operates in conformity with

the provisions of the laws of that country, as evidenced by its articles of incorporation (or equivalent documents of constitution or association) and its registration documents, as the case may be. This criterion also shall apply to the determination of the nationality of proposed sub-contractors or sub-consultants for any part of the Contract including related Services.

- 4.4 A Bidder that has been sanctioned by the Bank in accordance with the above ITB 3.1, including in accordance with the Bank's Guidelines on Preventing and Combating Corruption in Projects Financed by IBRD Loans and IDA Credits and Grants ("Anti-Corruption Guidelines"), shall be ineligible to be prequalified for, bid for, or be awarded a Bank-financed contract or benefit from a Bank-financed contract, financially or otherwise, during such period of time as the Bank shall have determined. The list of debarred firms and individuals is available at the electronic address **specified in the BDS**.
- 4.5 Bidders that are Government-owned enterprises or institutions in the Employer's Country may participate only if they can establish that they (i) are legally and financially autonomous (ii) operate under commercial law, and (iii) are not dependent agencies of the Employer. To be eligible, a government-owned enterprise or institution shall establish to the Bank's satisfaction, through all relevant documents, including its Charter and other information the Bank may request, that it: (i) is a legal entity separate from the government (ii) does not currently receive substantial subsidies or budget support; (iii) operates like any commercial enterprise, and, inter alia, is not obliged to pass on its surplus to the government, can acquire rights and liabilities, borrow funds and be liable for repayment of its debts, and can be declared bankrupt; and (iv) is not bidding for a contract to be awarded by the department or agency of the government which under their applicable laws or regulations is the reporting or supervisory authority of the enterprise or has the ability to exercise influence or control over the enterprise or institution.
- 4.6 A Bidder shall not be under suspension from bidding by the Purchaser as the result of the operation of a Bid-Securing Declaration.
- 4.7 Firms and individuals may be ineligible if so indicated in Section V and (a) as a matter of law or official regulations, the Borrower's country prohibits commercial relations with that country, provided that the Bank is satisfied that such exclusion does not preclude effective competition for the supply of goods or the contracting of works or services required; or (b) by an act of compliance with a decision of the United Nations Security Council taken under Chapter VII of the Charter of the United Nations, the Borrower's country prohibits any import of goods or contracting of works or services from that country, or any payments to any country, person, or entity in that country.
- 4.8 Bidder shall provide such evidence of eligibility satisfactory to

the Employer, as the Employer shall reasonably request.

4.9 Not used

5. Eligible Materials, Equipment and Services

5.1 The materials, equipment and services to be supplied under the Contract and financed by the Bank may have their origin in any country subject to the restrictions specified in Section V, Eligible Countries, and all expenditures under the Contract will not contravene such restrictions. At the Employer's request, Bidders may be required to provide evidence of the origin of materials, equipment and services.

B. Contents of Bidding Document

6. Sections of Bidding Document

6.1 The Bidding Document consist of Parts 1, 2, and3, which include all the Sections indicated below, and should be read in conjunction with any Addenda issued in accordance with ITB 8.

PART 1 Bidding Procedures

Section I - Instructions to Bidders (ITB)

Section II - Bid Data Sheet (BDS)

Section III - Evaluation and Qualification Criteria

Section IV - Bidding Forms

Section V - Eligible Countries

Section VI- Bank Policy-Corrupt and Fraudulent Practices

PART 2 Work's Requirements

Section VII - Works Requirements

PART 3 Conditions of Contract and Contract Forms

Section VIII - General Conditions of Contract (GCC)

Section IX - Particular Conditions of Contract (PCC)

Section X - Contract Forms

6.2 The Invitation for Bids issued by the Employer is not part of the Bidding Document.

6.3 Unless obtained directly from the Employer, the Employer is not responsible for the completeness of the Bidding Documents, responses to requests for clarification, the minutes of the pre-Bid meeting (if any), or Addenda to the Bidding Documents in accordance with ITB 8. In case of any contradiction, documents obtained directly from the Employer shall prevail.

6.4 The Bidder is expected to examine all instructions, forms, terms, and specifications in the Bidding Documents and to furnish with its bid all information and documentation as required by the Bidding Documents.

7 Clarification of Bidding

7.1 The electronic bidding system **specified in the BDS** provides for online clarifications. A prospective Bidder requiring any

**Document, Site
Visit, Pre-Bid
Meeting**

clarification on the Bidding Document may notify the Employer online or raise his inquiries during the pre-bid meeting if provided for in accordance with ITB 7.4. Clarifications requested through any other mode shall not be considered by the Employer. The Employer will respond to any request for clarification, provided that such request is received prior to the deadline for submission of bids, within a period **specified in the BDS**. Description of clarification sought and the response of the Employer shall be uploaded for information of all Bidders without identifying the source of request for clarification. Should the clarification result in changes to the essential elements of the Bidding Documents, the Employer shall amend the Bidding Documents following the procedure under ITB 8 and ITB 22.2.

- 7.2 The Bidder is advised to visit and examine the Site of Works and its surroundings and obtain for itself, on its own risk and responsibility, all information that may be necessary for preparing the *bid* and entering into a contract for construction of the Works. The costs of visiting the Site shall be at the Bidder's own expense.
- 7.3 The Bidder and any of its personnel or agents will be granted permission by the Employer to enter upon its premises and lands for the purpose of such visit, but only upon the express condition that the Bidder, its personnel, and agents will release and indemnify the Employer and its personnel and agents from and against all liability in respect thereof, and will be responsible for death or personal injury, loss of or damage to property, and any other loss, damage, costs, and expenses incurred as a result of the inspection.
- 7.4 If so, **specified in the BDS**, the Bidder's designated representative is invited to attend a pre-bid meeting. The purpose of the meeting will be to clarify issues and to answer questions on any matter that may be raised at that stage.
- 7.5 The Bidder is requested, to submit any questions only through the e-procurement portal, not later than one week before the meeting. Clarifications requested through any other mode shall not be considered by the Employer.
- 7.6 Minutes of the pre-bid meeting, including the text of the questions raised, without identifying the source, and the responses given, together with any responses prepared after the meeting, will be uploaded online on e-procurement system. Any modification to the Bidding Documents that may become necessary as a result of the pre-bid meeting shall be made by the Employer exclusively through the issue of an addendum pursuant to ITB 8 and not through the minutes of the pre-bid meeting. It is the bidder's responsibility to check on the e-procurement system, for any addendum/amendment/corrigendum to the bidding documents.

- 7.7 Nonattendance at the pre-bid meeting will not be a cause for disqualification of a Bidder.
- 8 Amendment of Bidding Document**
- 8.1 At any time prior to the deadline for submission of bids, the Employer may amend the Bidding Documents by issuing addenda. The addendum will appear on the e-procurement system under “Latest Corrigendum” and email notification is also automatically sent to those bidders who have started working on the tender, or as **otherwise specified in BDS**.
- 8.2 Any addendum thus issued shall be part of the Bidding Document and shall be deemed to have been communicated to all bidders.
- 8.3 To give prospective Bidders reasonable time in which to take an addendum into account in preparing their bids, the Employer may, at its discretion, extend the deadline for the submission of bids, pursuant to ITB 22.2

C. Preparation of Bids

- 9 Cost of Bidding**
- 9.1 The Bidder shall bear all costs associated with the preparation and submission of its Bid, and the Employer shall in no case be responsible or liable for those costs, regardless of the conduct or outcome of the bidding process.
- 10 Language of Bid**
- 10.1 The Bid, as well as all correspondence and documents relating to the bid exchanged by the Bidder and the Employer, shall be written in English language. Supporting documents and printed literature that are part of the Bid may be in another language provided they are accompanied by an accurate translation of the relevant passages into English language, in which case, for purposes of interpretation of the Bid, such translation shall govern.
- 11 Documents Comprising the Bid**
- 11.1 The Bid shall comprise two Parts, namely the Technical Part and the Financial Part. These two Parts shall be submitted simultaneously.
- 11.2 The Technical Part shall contain the following:
- (a) Letter of Bid – Technical Part;
 - (b) completed Schedules, in accordance with ITB 12, as **specified in BDS**;
 - (c) Bid Security, in accordance with ITB 19;
 - (d) alternative bids – technical part, if permissible, in accordance with ITB 13;
 - (e) written confirmation authorizing the signatory of the Bid to commit the Bidder, in accordance with ITB 20.2;
 - (f) documentary evidence in accordance with ITB 17 establishing the Bidder’s qualifications to perform the contract, if its Bid is accepted;

- (g) Technical Proposal in accordance with ITB 16;
- (h) Construction methodology proposed as detailed in Para 1.1 of Section III Evaluation Criteria; and
- (i) Bids submitted by a JV (where permitted) shall include a copy of the Joint Venture Agreement entered into by all members. Alternatively, a letter of intent to execute a Joint Venture Agreement in the event of a successful bid shall be signed by all members and submitted with the bid, together with a copy of the proposed Agreement.
- (j) Any other document **required in the BDS**.

11.3 The **Financial Part** shall contain the following:

- (a) **Letter of Bid – Financial Part:** prepared in accordance with ITB 12 and ITB 14;
- (b) **Bill of Quantities** completed online in accordance with ITB 12 and ITB 14;
- (c) **Alternative Bid - Financial Part:** if permissible in accordance with ITB 13; and
- (d) any other document **required in the BDS**.

11.4 The Technical Part shall not include any information related to the Bid price. Where material financial information related to the Bid price is contained in the Technical Part the Bid shall be declared non-responsive.

11.5 The Bidder shall furnish in the Letter of Bid – Financial Part information on commissions and gratuities, if any, paid or to be paid to agents or any other party relating to this Bid.

12 Process of Bid Submission

12.1 The Letter of Bid– Technical Part, Letter of Bid – Financial Part, Schedules, and Bill of Quantities, shall be prepared using the relevant forms in Section IV (Bidding Forms). The forms must be completed without any alterations to the text, and no substitutes shall be accepted. All blank spaces shall be filled in with the information requested.

12.2 Entire Bid including the Letter of Bid and filled-up Bill of Quantity shall be submitted online on e-procurement system specified in ITB 7.1. Details and process of online submission of the tender and relevant documents are given in the website mentioned above. Scanned copies of documents listed in ITB clauses 11 and 12.3 should also be uploaded on this website.

12.3 **Submission of Original Documents:** The bidders are required to submit (i) Bank draft towards the cost of bid document and the GST amount separately; (ii) original bid security in approved form; (iii) original affidavit regarding correctness of information furnished with bid document; and (iv) original affidavit regarding the validity of rates, with the office specified in the BDS, before the opening of the technical part of the Bid, either by registered/speed post/courier or by hand, failing which the bids will be declared non-responsive. Due to valid

unavoidable circumstances, if bidder(s) fails to submit the hard copies of aforesaid original documents before the opening of technical bid, the bidder must submit these original documents within the stipulated time as intimated by the Purchaser. If bidder(s) will not provide these original documents within prescribed time as given by the Purchaser, his/their bid(s) will be declared as non-responsive and in such situation Purchaser may take any action against such bidder(s).

- 13 Alternative Bids** 13.1 Bidders shall submit offers that comply with the requirements of the bidding documents, including the basic technical design as indicated in the drawing and specifications. Alternatives will not be considered.
- 14 Bid Prices and Discounts**
- 14.1 The prices and discounts (including any price reduction) quoted by the Bidder in the Letter of Bid - Financial Part, and in the Schedules shall conform to the requirements specified below.
- 14.2 The Bidder shall submit a bid for the whole of the works described in ITB 1.1 by filling in prices for all items of the Works (both in figures and words), as identified in Section IV, Bidding Forms along with the total bid price (both in figures and words). The Bidder shall fill in rates and prices for all items of the Works described in the Bill of Quantities. **Items against which no rate or price is entered by the Bidder will not be paid for by the Employer when executed and shall be deemed covered by the rates for other items and prices in the Bill of Quantities.** Corrections if any in the bid can be carried out by editing the information before electronic submission on e-procurement portal.
- 14.3 The price to be quoted in the Letter of Bid - Financial Part in accordance with ITB 12.1, shall be the total price of the Bid, excluding any discounts offered.
- 14.4 Unconditional discounts, if any, and the methodology for their application shall be quoted in the Letter of Bid - Financial Part, in accordance with ITB 12.1.
- 14.5 Unless otherwise **specified in the BDS** and the Conditions of Contract, the rates and prices quoted by the Bidder shall be fixed
- 14.6 If so indicated in ITB 1.1, bids are invited for individual lots (contracts) or for any combination of lots/contracts (packages). Bidders wishing to offer any price reduction for the award of more than one Contract shall specify in their bid the price reductions applicable to each package, or alternatively, to individual Contracts within the package. Price reductions or discounts shall be submitted in accordance with ITB 14.4, provided the bids for all lots/contracts are submitted and opened at the same time.
- 14.7 All duties, taxes, and other levies payable by the Contractor under the Contract, or for any other cause, as applicable on the

deadline for submission of Bids, shall be included in the rates and prices and the total bid price submitted by the Bidder.

- 14.8 Bidders may like to ascertain availability of excise/custom duty exemption benefits available in India to the contracts financed under World Bank loan/credits. They are solely responsible for obtaining such benefits which they have considered in their bid and in case of failure to receive such benefits for reasons whatsoever, the Employer will not compensate the bidder (contractor). The bidder shall furnish alongwith his bid a declaration to this effect in the Declaration Format provided in Section IV of the bidding documents.

Where the bidder has quoted taking into account such benefits, it must give all information required for issue of certificates in terms of the Government of India Central Excise Notification and Customs Notification as per form stipulated in Section IV. In case the bidder has not provided the required information or has indicated to be furnished later on in the Declaration Format, the same shall be construed that the goods/construction equipment for which certificate is required is Nil.

To the extent the Employer determines the quantity indicated therein are reasonable keeping in view the quantities in bill of quantities, construction program and methodology, the certificates will be issued within 60 days of signing of the contract and no subsequent changes will be permitted. In case of materials pertaining to Variation items and quantities the certificate shall be issued only on request from the contractor when in need and duly certified by the Project Manager.

No certificate will be issued for items where no quantity/capacity of equipment is indicated in the statement.

If the bidder has considered the customs/excise duty exemption for materials/construction equipment to be bought for the work, the bidder shall confirm and certify that the Employer will not be required to undertake any responsibilities of the Government of India Scheme or the said exemptions being available during the contract execution, except issuing the required certificate. The bids which do not conform to the above provisions or any condition by the bidder which makes the bid subject to availability of customs/excise duty exemption for materials/construction equipment or compensation on withdrawal of any variations to the said exemptions will be treated as non-responsive and rejected.

Any delay in procurement of the construction equipment/machinery/goods as a result of the above shall not be a cause for granting any extension of time.

15 Currencies of Bid and Payment

- 15.1 The unit rates and prices shall be quoted by the Bidder and shall be paid for, entirely in Indian Rupees.

16 Documents Comprising the

- 16.1 The Bidder shall furnish a Technical Proposal in the Technical Part of the Bid, including a statement of work methods,

-
- Technical Proposal** equipment, personnel, schedule and any other information as per details stipulated in Section IV(Bidding Forms), in sufficient detail to demonstrate the adequacy of the Bidders' proposal to meet the work requirements and the completion time.
- 17 Documents Establishing the Qualifications of the Bidder**
- 17.1 To establish Bidder's eligibility in accordance with ITB 4, Bidders shall complete the Letter of Bid – Technical Part, included in Section IV, Bidding Forms.
- 17.2 To establish its qualifications to perform the Contract in accordance with Section III (Evaluation and Qualification Criteria) the Bidder shall provide the complete information as requested in the corresponding information sheets included in Section IV (Bidding Forms).
- 18 Period of Validity of Bids**
- 18.1 Bids shall remain valid for the period **specified in the BDS** after the bid submission deadline date prescribed by the Purchaser in accordance with ITB 22.1. A bid valid for a shorter period shall be rejected by the Employer as non-responsive.
- 18.2 In exceptional circumstances, prior to the expiration of the bid validity period, the Employer may request bidders to extend the period of validity of their bids. The request and the responses shall be made in writing. If a Bid Security is requested in accordance with ITB Clause 19, it shall also be extended for a corresponding period. A Bidder may refuse the request without forfeiting its Bid Security. A Bidder granting the request shall not be required or permitted to modify its bid, except as provided in ITB Sub-Clause 18.3.
- 18.3 If the award is delayed by a period exceeding fifty-six (56) days beyond the expiry of the initial bid validity, the Contract price shall be determined as follows:
- (a) In the case of fixed price contracts, the Contract price shall be the bid price adjusted by the factor specified in the BDS for each week or part of the week that has elapsed from the expiration of the initial bid validity to the date of notification of award to the successful bidder. In case of adjustable price contracts, no adjustment shall be made.
- (b) In the case of adjustable Price contract, no adjustment shall be made.
- (c) In any case, bid evaluation shall be based on the bid Price without taking into consideration the applicable correction from those indicated above.
- 19 Bid Security**
- 19.1 Unless otherwise **specified in the BDS**, the Bidder shall furnish as part of the Technical Part of its bid, in original form, a bid security for the amount **shown in BDS**, for this particular work.
- 19.2 The bid security shall be a demand guarantee, at the Bidder's option, in any of the following forms:
- (a) an unconditional bank guarantee, issued by a

Nationalized/Scheduled bank located in India;

- (b) an irrevocable letter of credit issued by a Nationalized or Scheduled bank located in India;
- (c) a cashier's or certified check; or demand draft from a Nationalized or Scheduled Bank located in India;
- (d) another security **indicated in the BDS.**

In case of a bank guarantee, the bid security shall be submitted using the Bid Security form included in the Section IV (Bidding Forms). The form must include the complete name of the Bidder. The bid security shall be valid for one twenty (120) days beyond the original validity period of the bid, or beyond any period of extension if requested under ITB 18.2.

19.3 If a Bid Security is specified pursuant to ITB 19.1, any bid not accompanied by a substantially responsive Bid Security shall be rejected by the Employer as non-responsive.

19.4 If a bid security is specified pursuant to ITB 19.1, the bid security of unsuccessful Bidders shall be returned as promptly as possible upon the successful Bidder's signing the contract and furnishing of the performance security pursuant to ITB 45.

19.5 If a bid security is specified pursuant to ITB 19.1, the bid security of the successful Bidder shall be returned as promptly as possible once the successful Bidder has signed the Contract and furnished the required performance security.

19.6 The bid security may be forfeited:

(a) if a Bidder withdraws/modifies/substitutes its bid during the period of bid validity specified by the Bidder on the Letter of Bid- Technical Part and repeated in the Letter of Bid - Financial Part, or any extension thereto provided by the Bidder in accordance with ITB 18.2 or

(b) if the Bidder does not accept the correction of its Bid Price pursuant to ITB 36 or

(c) if the successful Bidder fails to:

(i) sign the Contract in accordance with ITB 44; or

furnish a performance security in accordance with ITB 45.

19.7 The Bid Security of a JV shall be in the name of the JV that submits the bid. If the JV has not been constituted into a legally-enforceable JV, at the time of bidding, the Bid Security shall be in the names of all future members as named in the letter of intent mentioned in ITB 4.1.2 and ITB 11.2.

20 Format and Signing of Bid

20.1 The Bidder shall prepare the Bid as per details given in ITB 21.

20.2 The bid shall be signed by a person duly authorized to sign on behalf of the Bidder. This authorization shall be uploaded

along with the Bid.

- 20.3 In case the Bidder is a JV, the Bid shall be signed by an authorized representative of the JV on behalf of the JV, and so as to be legally binding on all the members as evidenced by a power of attorney signed by their legally authorized representatives
- 20.4 Documents establishing authority to sign the bid on behalf of the JV shall be uploaded along with the bid.
- 20.5 The Bidder shall furnish information as described in the letter of Bid on commissions or gratuities, if any, paid or to be paid to agents relating to this Bid, and to contract execution if the Bidder is awarded the contract.

D. Online Submission and Opening of Bids

21 Preparation of Bids

- 21.1 Bids, both Technical and Financial Parts, shall be submitted online on the e-procurement system specified in BDS 7.1. Detailed guidelines for viewing bids and submission of online bids are given on the website. The Invitation for Bids under this Project is published on this website. Any citizen or prospective bidder can logon to this website and view the Invitation for Bids and can view the details of works for which bids are invited. A prospective bidder can submit its bid online; however, the bidder is required to have enrolment/registration in the website, and should have valid Digital Signature Certificate (DSC) in the form of smart card/e-token obtained from any certifying agency authorised by the Government of India (for class of DSC **specified in BDS**). The bidder should register in the website using the relevant option available. Then the Digital Signature registration has to be done with the e-token, after logging into the website. The bidder can then login the website through the secured login by entering the password of the e-token & the user id/ password chosen during registration. After getting the bid schedules, the Bidder should go through them carefully and submit the specified documents, along with the bid, otherwise the bid will be rejected.
- 21.2 The completed bid comprising of documents indicated in ITB 12, should be uploaded on the e-procurement portal along with scanned copies of requisite certificates as are mentioned in different sections in the bidding document and scanned copy of the bid security.
- 21.3 All the documents are required to be signed digitally by the bidder. After electronic on line bid submission, the system generates a unique bid identification number which is time stamped as per server time. This shall be treated as acknowledgement of bid submission.
- 21.4 Physical, E-mail, Telex, Cable or Facsimile bids will be

- rejected as non-responsive.
- 22 Deadline for Submission of Bids**
- 22.1 Bids must be uploaded online no later than the date and time **indicated in the BDS**.
- 22.2 The Employer may, at its discretion, extend the deadline for the submission of bids by amending the Bidding Document in accordance with ITB 8, in which case all rights and obligations of the Employer and Bidders previously subject to the deadline shall thereafter be subject to the deadline as extended.
- 23 Late Bids**
- 23.1 The electronic bidding system would not allow any late submission of bids after due date & time as per server time.
- 24 Withdrawal, Substitution, and Modification of Bids**
- 24.1 Bidders may modify their bids by using the appropriate option for bid modification on e-procurement portal, before the deadline for submission of bids. For this the bidder need not make any additional payment towards the cost of bid document. For bid modification and consequential re-submission, the bidder is not required to withdraw his bid submitted earlier. The last modified bid submitted by the bidder within the bid submission time shall be considered as the bid. For this purpose, modification/withdrawal by other means will not be accepted. In online system of bid submission, the modification and consequential re-submission of bids is allowed any number of times. A bidder may withdraw his bid by using the appropriate option for bid withdrawal, before the deadline for submission of bids, however, if the bid is withdrawn, re-submission of the bid is not allowed (or allowed **if specified in BDS**).
- 24.2 Bids requested to be withdrawn in accordance with ITB 24.1 shall not be opened.
- 24.3 No bid may be withdrawn, substituted, or modified in the interval between the deadline for submission of bids and the expiration of the period of bid validity specified by the Bidder on the Letter of Bid (Technical Part and/or Financial Part) or any extension thereof.

E. Public Opening of Technical Parts of Bids

- 25 Public Opening of Technical Parts of Bids**
- 25.1 The Employer shall publicly open Technical Parts of all bids received by the deadline, at the date, time and place **specified in the BDS** in the presence of Bidders' designated representatives and anyone who choose to attend, and this could also be viewed by the bidders online. The Financial Parts of the bids shall remain unopened in the e-procurement system, until the subsequent public opening, following the evaluation of the Technical Parts of the Bids. In all cases, original documents submitted as specified in ITB 12.3 shall be first scrutinized, and Bids that do not comply with the provisions of ITB 12.3 will be declared non-responsive and will not be opened. Thereafter bidder's names, and such other details as

the Employer may consider appropriate will be notified online as Technical Part bid opening summary.

In the event of the specified date of bid opening being declared a holiday for the Employer, the bids will be opened at the appointed time and location on the next working day.

- 25.2 The electronic summary of the bid opening will be generated and uploaded online. The Employer will also prepare minutes of the Bid opening, including the information disclosed and upload the same for viewing online. Only Technical Parts of Bids that are opened at Bid opening shall be considered further for evaluation.

F. Evaluation of Bids – General Provisions

- 26 Confidentiality**
- 26.1 Information relating to the examination, evaluation, comparison, and post-qualification of bids and recommendation of contract award, shall not be disclosed to Bidders or any other persons not officially concerned with such process until information on Contract award is communicated to all Bidders in accordance with ITB 44.
- 26.2 Any attempt by a Bidder to influence the Employer in the evaluation of the bids or Contract award decisions may result in the rejection of its bid.
- 26.3 Notwithstanding ITB 26.2, from the time of bid opening to the time of Contract award, if any Bidder wishes to contact the Employer on any matter related to the bidding process, it may do so in writing.
- 27 Clarification of Bids**
- 27.1 To assist in the examination, evaluation, and comparison of the bids, and qualification of the Bidders, the Employer may, at its discretion, ask any Bidder for a clarification of its bid including breakdown of unit rates, giving a reasonable time for response. Any clarification submitted by a Bidder that is not in response to a request by the Employer shall not be considered. The Employer's request for clarification and the response shall be in writing. No change, including any voluntary increase or decrease in the prices or substance of the bid shall be sought, offered, or permitted, except to confirm the correction of arithmetic errors discovered by the Employer in the evaluation of the bids, in accordance with ITB 36.
- 27.2 If a Bidder does not provide clarifications of its bid by the date and time set in the Employer's request for clarification, its bid may be rejected.
- 28 Deviations, Reservations, and Omissions**
- 28.1 During the evaluation of bids, the following definitions apply:
- (a) "Deviation" is a departure from the requirements specified in the Bidding Document;
 - (b) "Reservation" is the setting of limiting conditions or withholding from complete acceptance of the requirements

specified in the Bidding Document; and

- (c) "Omission" is the failure to submit part or all of the information or documentation required in the Bidding Document.

- 29 Nonconformities, Errors, and Omissions**
- 29.1 Provided that a bid is substantially responsive, the Employer may waive any non-conformities in the bid which do not constitute a material deviation, reservation or omission.
- 29.2 Provided that a bid is substantially responsive, the Employer may request that the Bidder submit the necessary information or documentation, within a reasonable period of time, to rectify nonmaterial nonconformities in the bid related to documentation requirements. Requesting information or documentation on such nonconformities shall not be related to any aspect of the price or substance of the bid. Failure of the Bidder to comply with the request may result in the rejection of its bid.
- 29.3 Provided that a bid is substantially responsive, the Employer shall rectify quantifiable nonmaterial nonconformities related to the Bid Price. To this effect, the Bid Price may be adjusted, for comparison purposes only, to reflect the price of a missing or non-conforming item or component in the manner **specified in the BDS**.

G. Evaluation of Technical Parts of Bids

- 30 Evaluation of Technical Parts**
- 30.1 In evaluating the Technical Parts of each Bid, the Purchaser shall use the criteria and methodologies listed in ITB 31, ITB 32, and Section III, Evaluation and Qualification Criteria. No other evaluation criteria or methodologies shall be permitted.
- 31 Determination of Responsiveness**
- 31.1 The Employer's determination of a Bid's responsiveness is to be based on the contents of the Bid itself, as defined in ITB 11.
- 31.2 A substantially responsive Bid is one that meets the requirements of the bidding document without material deviation, reservation, or omission. A material deviation, reservation, or omission is one that:
- (a) if accepted, would:
- (i) affect in any substantial way the scope, quality, or performance of the Works specified in the Contract; or
- (ii) limit in any substantial way, inconsistent with the bidding document, the Employer's rights or the Bidder's obligations under the proposed Contract; or
- (b) if rectified, would unfairly affect the competitive position of other Bidders presenting substantially responsive Bids.
- 31.3 The Employer shall examine the technical aspects of the Bid submitted in accordance with ITB 16, Technical Proposal, in particular, to confirm that all requirements of Section VII,

Works' Requirements have been met without any material deviation, reservation or omission.

31.3.1 The Employer shall examine the bids to confirm that all documents and technical documentation requested in ITB Clause 11 have been provided, and to determine the completeness of each document submitted.

31.4 If a Bid is not substantially responsive to the requirements of the bidding document, it shall be rejected by the Employer and may not subsequently be made responsive by correction of the material deviation, reservation, or omission.

32 Qualification of the Bidder

32.1 The Employer shall determine to its satisfaction whether the eligible Bidders that have submitted substantially responsive Bid - Technical Parts meet the qualifying criteria specified in Section III, Evaluation and Qualification Criteria.

32.2 The determination shall be based upon an examination of the documentary evidence of the Bidder's qualifications submitted by the Bidder, pursuant to ITB 17. The determination shall not take into consideration the qualifications of other firms such as the Bidder's subsidiaries, parent entities, affiliates, subcontractors (other than Specialized Subcontractors if permitted in the bidding document), or any other firm(s) different from the Bidder.

32.3 If a Bidder does not meet the qualifying criteria specified in Section III, Evaluation and Qualification Criteria, its Bid shall be rejected by the Employer and may not subsequently be made responsive by correction of the material deviation, reservation, or omission.

32.4 Only Bids that are both substantially responsive to the bidding document, and meet all Qualification Criteria shall have the Financial Parts of their Bids opened at the second public opening.

33 Subcontractors

33.1 Unless otherwise **stated in the BDS**, the Employer does not intend to execute any specific elements of the Works by subcontractors selected in advance by the Employer.

33.2 The Employer may permit subcontracting for certain specialized works as indicated in Section III. When subcontracting is permitted by the Employer, the specialized sub-contractor's experience shall be considered for evaluation. Section III describes the qualification criteria for subcontractors.

33.3 Bidders may propose subcontracting up to the percentage of total value of contracts or the volume of works as **specified in the BDS**. Subcontractors proposed by the Bidder shall be fully qualified for their parts of the Works.

H. Public Opening of Financial Parts of Bids

34 Public Opening

34.1 Following the completion of the evaluation of the Technical

**of Financial
Parts**

Parts of the Bids, and the Bank has issued its no objection (if applicable), the Employer shall notify in writing those Bidders who have failed to meet the Qualification Criteria and/or whose Bids were considered non-responsive to the requirements in the bidding document, advising them of the following information:

- (a) their Technical Part of Bid failed to meet the requirements of the bidding document;
- (b) their Financial Part of Bid shall not be opened; and
- (c) notify them of the date and time for public opening of the Financial Parts of the Bids. Financial Parts of the bids shall not be opened earlier than seven (7) days from the communication of technical evaluation results to the bidders.

34.2 The Employer shall, simultaneously, notify in writing those Bidders whose Technical Part have been evaluated as substantially responsive to the bidding document and met all Qualifying Criteria, advising them of the following information:

- (a) their Bid has been evaluated as substantially responsive to the bidding document and met the Qualification Criteria;
- (b) their Financial Part of Bid will be opened at the public opening of the Financial Parts; and
- (c) notify them of the date, time, and place of the second public opening of the Financial Parts of the Bids, as specified in the BDS.

34.3 The opening date should allow Bidders sufficient time to make arrangements for attending the opening. The Financial Part of the Bids shall be opened publicly in the presence of Bidders' designated representatives and anyone who choose to attend, and this could also be viewed by the bidders online. The bidder's names, the Bid prices, the total amount of each bid, per lot (contract) if applicable, including any discounts, and such other details as the Employer may consider appropriate, will be notified online by the Employer at the time of bid opening.

In the event of the specified date of bid opening being declared a holiday for the Employer, the bids will be opened at the appointed time and location on the next working day.

34.4 The electronic summary of the bid opening will be generated and uploaded online. The Employer will also prepare minutes of the Bid opening, including the information disclosed and upload the same for viewing online. Only Financial Part of Bids, Financial Parts of Alternative Bids and discounts that are opened and read out at Bid opening shall be considered further for evaluation.

I. Evaluation of Financial Parts of Bids

- | | |
|---|---|
| 35 Evaluation of Financial Parts | <p>35.1 To evaluate the Financial Part, the Employer shall consider the following:</p> <ul style="list-style-type: none"> (a) the Bid price, excluding Provisional Sums and the provision, if any, for contingencies in the Summary Bill of Quantities but excluding Daywork items, where priced competitively; (b) Not used; (c) price adjustment due to discounts offered in accordance with ITB 14.4; (d) Not used; (e) price adjustment due to quantifiable nonmaterial nonconformities in accordance with ITB 29.3; and (f) the additional evaluation factors as specified in Section III, Evaluation and Qualification Criteria. <p>35.2 The estimated effect of the price adjustment provisions of the Conditions of Contract, applied over the period of execution of the Contract, shall not be taken into account in Bid evaluation.</p> <p>35.3 If this bidding document allows Bidders to quote separate prices for different lots (contracts), and to award multiple contracts to a single Bidder, the methodology to determine the lowest evaluated price of the contract combinations, including any discounts offered in the Letter of Bid – Financial Part, is specified in Section III, Evaluation and Qualification Criteria</p> |
| 36 Correction of Arithmetical Errors | <p>36.1 The e-procurement system automatically calculates the total amount from unit rates and quantities and the system also automatically populates the amount in words from the amount in figures and therefore there is no scope of discrepancy and need for arithmetic correction.</p> |
| 37 Conversion to Single Currency | <p>37.1 Not used.</p> |
| 38 Margin of Preference | <p>38.1 Not used.</p> |
| 39 Comparison of Financial Parts | <p>39.1 The Employer shall compare the evaluated prices of all substantially responsive bids established in accordance with ITB 35.1 to determine the lowest evaluated bid.</p> |
| 40 Unbalanced or Front Loaded Bids | <p>40.1 If the bid, which results in the lowest Evaluated Bid Price, is seriously unbalanced, front loaded or substantially below updated estimates in the opinion of the Employer, the Employer may require the Bidder to produce detailed price analyses (with breakdown of unit rates) for any or all items of the Bill of Quantities, to demonstrate the internal consistency and justification of those prices with the construction methods and schedule proposed. After evaluation of the price analyses,</p> |

taking into consideration the schedule of estimated contract payments, the Employer may require that the amount of the performance security be increased at the expense of the Bidder to a level sufficient to protect the Employer against financial loss in the event of default of the successful Bidder under the Contract.

- 41 Employer’s Right to Accept Any Bid, and to Reject Any or All Bids** 41.1 The Employer reserves the right to accept or reject any bid, and to annul the bidding process and reject all bids at any time prior to contract award, without thereby incurring any liability to Bidders. In case of annulment, all documents submitted and specifically, bid securities, shall be promptly returned to the Bidders.

J. Award of Contract

- 42 Award Criteria** 42.1 Subject to ITB 41, the Employer shall award the Contract to the successful Bidder that meets the Qualification Criteria, whose offer has been determined to be the lowest evaluated bid and is substantially responsive to the Bidding Document.
- 43 Notification of Award** 43.1 Prior to the expiration of the period of bid validity, the Employer shall notify the successful Bidder, in writing, via the Letter of Acceptance included in the Contract Forms, that its bid has been accepted. The Letter of Acceptance shall specify the sum that the Employer will pay the Contractor in consideration of the execution and completion of the Works (hereinafter and in the Conditions of Contract and Contract Forms called “the Contract Price”).
- 43.2 Until a formal contract is prepared and executed, the notification of award shall constitute a binding Contract.
- 44 Signing of Contract, Publication of award and Recourse to unsuccessful Bidders** 44.1 The Contract Agreement shall incorporate all agreements between the Employer and the successful Bidder. It shall be kept ready in the office of the Employer for the signature of the Employer and the successful Bidder, within 21 days following the date of Letter of acceptance. Within 21 days of receipt of Letter of acceptance, the successful Bidder shall sign the Agreement and furnish the performance security in accordance with ITB Clause 45 and revised construction methodology. If the successful bidder is a JV, it shall also furnish the JV agreement duly signed by all the members, if it had submitted only a letter of intent to execute the JV agreement along with the bid.
- 44.2 The Employer within 3 weeks of issue of notification of award shall publish in a national website (<http://tenders.gov.in> or GoI Central Public Procurement Portal <https://eprocure.gov.in/cppppp/>) or on the Employer’s website with free access if available, or in the official gazette, the results identifying the bid and lot numbers and the following information: (i) name of each bidder who submitted the bid; (ii) bid prices as read out at bid opening; (iii) name and

evaluated prices of each bid that was evaluated; (iv) name of bidders whose bids were rejected and the reasons for their rejection; and (v) name of the winning bidder, and the price it offered, as well as the duration and summary scope of the contract awarded.

- 44.3 The Employer shall promptly respond in writing to any unsuccessful Bidder who, after publication of contract award, requests the Employer in writing to explain on which grounds its bid was not selected.
- 45 Performance Security**
- 45.1 Within twenty-one (21) days of the receipt of notification of award from the Employer, the successful Bidder shall furnish the performance security in accordance with the conditions of contract, subject to ITB 40.1, using for that purpose the Performance Security and ESHS Security Forms included in Section X (Contract Forms). The performance security of a Joint Venture shall be in the name of the Joint Venture specifying the names of all members.
- 45.2 Failure of the successful Bidder to submit the above-mentioned Performance Security or to sign the Contract Agreement shall constitute sufficient grounds for the annulment of the award and forfeiture of the bid security. In that event the Employer may award the Contract to the next lowest evaluated Bidder whose offer is substantially responsive and is determined by the Employer to be qualified to perform the Contract satisfactorily.
- 45.3 Upon the successful Bidder's signing the Agreement and furnishing of the Performance Security pursuant to ITB Clause 45.1, the Employer shall promptly notify the name of the winning bidder to each unsuccessful bidder and shall discharge the Bid Securities of the bidders pursuant to ITB Clause 19.4 and 19.5.
- 46 Adjudicator or Dispute Review Expert**
- 46.1 The Employer proposes the person **named in the BDS** to be appointed as Adjudicator (or Dispute Review Expert) under the Contract, at the daily rate **specified in the BDS**, plus reimbursable expenses (actual boarding, lodging, travel and other incidental expenses). If the Bidder disagrees with this proposal, the Bidder should so state in Letter of Bid. If, in the Letter of Acceptance, the Employer does not agree on the appointment of the Adjudicator [or Disputes Review Expert] proposed by the Bidder, the Employer will request the Appointing Authority designated in the Particular Conditions of Contract (PCC) pursuant to Clause 23.1 of the General Conditions of Contract (GCC), to appoint the Adjudicator [or Disputes Review Expert].

Section II - Bid Data Sheet (BDS)

A. General

ITB 1.1	The Employer is: <i>Superintending Engineer, Research Circle, Irrigation Research institute, Roorkee-247667</i>
ITB 1.1	The name of the work is: <i>Drilling and installation of 66 nos. groundwater monitoring wells and construction of 66 nos. Protection works for DWLR telemetry system to monitor groundwater level and quality under National Hydrology Project (NHP) in Uttarakhand State.</i> IFB No. 11/SE(R)/NHP/e-tender/2020-21 Dated 09.04.2021
ITB 2.1	The Borrower is Government of India. Loan agreement amount is US\$ 175 million
ITB 2.1	The name of the Project is: National Hydrology Project
ITB 4.1.1	Bids from Joint ventures are acceptable.
ITB 4.1.2 (a)	Numbers of members/firms in a joint venture shall not be more than two including the lead partner.
ITB 4.1.2(g)	A Bidder may be a firm that is a private entity, a government-owned entity—subject to ITB 4.5—or any combination of such entities in the form of a joint venture (JV) under an existing agreement or with the intent to enter into such an agreement supported by a letter of intent. In the case of a joint venture, all members shall be jointly and severally liable for the execution of the Contract in accordance with the Contract terms. The JV shall nominate a Representative who shall have the authority to conduct all business for and on behalf of any and all the members of the JV during the bidding process and, in the event the JV is awarded the Contract, during contract execution.
ITB 4.4	A list of debarred firms and individuals is available at the Bank’s external website www.worldbank.org/debarr .
B. Contents of Bidding Documents	
ITB 7.1	Electronic –Procurement System The Employer shall use the following electronic-procurement system to manage this Bidding process: www.uktenders.gov.in Requests for clarification should be received by the Employer no later than 1 day prior before Pre – Bid Meeting date i.e., 19.04.2021.
ITB 7.1 (a)	A pre-bid meeting will be held on 19.04.2021 at 1.30 PM through video conference to clarify the issues and to answer questions on any matter that may be raised at the stage as stated in ITB clause 7.1 of “Instructions to Bidders” of the bidding documents. All prospective bidder(s) are requested

	to submit his query, if any, through email before 19.04.2021. Contact Persons: Sh. Shankar Kumar Saha (Mobile: 8826758368) Sh. Damodar Singh (Mobile: 8299743596) Sh. Giresh Chandra (Mobile: 8791226413)
ITB 8.1	The addendum will appear on the e-procurement system under latest corrigendum in www.uktender.gov.in and email notification is also automatically sent to those bidders who have started working on this tender.
C. Preparation of Bids	
ITB 11.2(b)	The following schedules shall be submitted alongwith the bid: All Bidding Forms as per Section IV to be submitted along with the bid.
ITB 11.2 (c)	Bid security, in accordance with ITB 19.1
ITB 11.2 (j)	The Bidder shall submit with its bid the following additional documents: (i) Contractor Registration certificate as per IFB, if applicable (ii) Attested copy of valid Identity Card. (iii) Attested copy of Machineries, Tools and plants (iv) Comprehensive and concise Environmental, Social, Health and Safety Management Strategies and Implementation Plans including Code of Conduct that will apply to its employees and subcontractors, to ensure compliance with its Environmental, Social, Health and Safety (ESHS) obligations including compliance with applicable Laws/ Rules/ Regulations for protection of environment, public health and safety, and the applicable parts of the Environment Management Plan of the project under the contract. (v) Experience: Attested copy of Work orders and Completion Certificates of similar works executed during the last 3 years i.e., July 2017 to July 2020 (vi) Attested copy of Work Orders for ongoing Works and existing commitments to be completed in the next 2 years i.e., July'2022. (vii) Legal Identity (viii) Key Plant and Equipment (ix) Liquid Asset and Credit facility (x) Proof of GST Registration Number and PAN Number (xi) Allotment EPF code Number from employee provident fund commissioner, and latest copy of challan of deposit of EPF of the employees, if applicable.
ITB 11.3 (d)	The Bidder shall submit the following additional documents in its Bid: Nil
ITB 12	Note for Bidders: Bidders have to submit the bids on the e-procurement portal along with the relevant required documents. For this purpose, the

	bidders shall fill up online, the forms that are available for online filling on the e-portal. The rest of the forms shall be downloaded by the bidders and filled up. The filled-up pages shall then be scanned and uploaded on the e-procurement portal along with the scanned copies of the supporting documents.
ITB 12.3	For submission of original documents, the Purchaser's address is: Superintending Engineer, Research Circle, Irrigation Research Institute, Roorkee P.O. Roorkee, District-Haridwar, Uttarakhand-247667 INDIA Telephone: 91-1332-265174 Facsimile number: 01332-262792, 01332-262487 E-mail: uttarkhandwrd@gmail.com
ITB 13.1	Alternative bids <i>shall not be</i> permitted.
ITB 14.5	The prices quoted by the Bidder "shall not be" subject to adjustment during the performance of the Contract.
ITB 18.1	The bid validity period shall be: 120 days.
ITB 18.3 (a)	The factor is 1.0007692 per week (multiplicative)
ITB 19.1	Bid shall include a Bid Security (issued by bank) included in Section IV Bidding Forms. Bid Security shall be valid for 165 days from the date of opening of financial bid. The Bidder shall furnish a bid security in the amount of Rs 5,40,000/- (Rs. Five Lakh Forty Thousand only)
ITB 19.2 (d)	Other types of acceptable securities are: Fixed Deposit/Time Deposit certificate issued by a Nationalized or Scheduled Bank located in India for equivalent or higher values are acceptable as bid security provided it is pledged in favour of Executive Engineer, Design Division, IDO, Roorkee and such pledging has been noted and suitably endorsed by the bank issuing the certificate. Bank guarantee in prescribed Performa as per annexure-1 from any Nationalized/ Scheduled Bank and valid for 180 (one hundred eighty) days from the date of receipt of tender or Bank Draft or Fixed Deposits of Scheduled Bank duly pledged, issues of National Saving Certificate or 3/5 years Post office Time Deposit duly pledged from any post office in favour of Executive Engineer, Design Division, IDO, Roorkee .
ITB 20.2	The written confirmation of authorization to sign on behalf of the Bidder shall consist of: <i>Legally valid Power of Attorney is required to demonstrate the authority of the signatory to sign the Bid.</i> (Scanned copy to be submitted alongwith the bid)
D. Online Submission and Opening of Bids	

ITB 21.1	Class of DSC required is: Refer https://uktenders.gov.in
ITB 22.1	For bid submission purposes, the Purchaser's address is: https://uktenders.gov.in The deadline for uploading of bids is: Date: 12.05.2021: 15:00 hours for online submission Date: 12.05.2021: 15:00 hours for original Submission
ITB 24.1	Re-submission of the bid is allowed till the final date and time of submission.
E. Public Opening of Technical Parts of Bids	
ITB 25.1	The online opening of the Technical Parts of Bids shall take place at: Office of the Superintending Engineer, Research Circle, Irrigation Research Institute, Roorkee, District-Haridwar, Uttarakhand-247667 INDIA Date: 12.05.2021 Time: 3:30 PM
F. Evaluation of Bids – General Provisions	
ITB 29.3	The adjustment shall be based on the highest price of the item or component as quoted in other substantially responsive Bids, subject to a maximum of the estimated price of the item. If the price of the item or component cannot be derived from the price of other substantially responsive Bids, the Employer shall use its best estimate.
G. Evaluation of Technical Parts of Bids	
ITB 33.1	At this time the Employer “does not intend” to execute certain specific parts of the Works by sub-contractors selected in advance.
ITB 33.2	NA.
ITB 33.3	NA
H. Public Opening of Financial Parts of Bids	
ITB 34.2 (c)	Following the completion of the evaluation of the Technical Parts of the Bids, the Purchaser will notify all those bidders; who have successfully qualified in the 1 st part of the bidding process, i.e. the technical evaluation; of the date and time of the public opening of Financial Part. The online opening of the Financial Part of bids (for technically qualified bidders) shall take place at: Office of the Superintending Engineer, Research Circle,

	<p>Irrigation Research Institute, Roorkee, District-Haridwar, Uttarakhand-247667 INDIA</p> <p>Telephone: 91-1332-265174 E-mail: uttarkhandwr@gmail.com</p> <p>Date & Time: Will be declare later</p>
J. Award of Contract	
ITB 45.1 and 45.2	<p>The successful Bidder shall also be required to submit an Environmental, Social, Health and Safety (ESHS) Performance Security.</p> <p><i>[Note: throughout this bidding document the term 'performance security', unless the context clearly indicates otherwise, means and includes both 'the performance security and the ESHS performance security' to be submitted by the successful bidder in the amounts specified in GCC/ PCC 50]</i></p>
ITB 46.1	<p>The Adjudicator/Dispute Review Expert proposed by the Employer is: Shri Rajendra Chalisgaonkar, Engineer-in-Chief (Retd.), Irrigation Department, Govt. of Uttarakhand. The daily fee for this proposed Adjudicator/Dispute Review Expert shall be: Rs. 5000.00. The biographical data of the proposed Adjudicator/Dispute Review Expert is annexed as Annexure A.</p> <hr/> <p><i>[provide relevant information, such as education, experience, age, nationality, and present position; attach additional pages as necessary]</i></p>

Annexure A**Curriculum Vitae**

Rajendra Chalisgaonkar graduated in Civil Engg. with honours and second rank in 1978 from Madhav Institute of Technology & Science, Gwalior and then obtained M.E.(Structural Engg.) in 1982 from Univ. of Roorkee, now IIT Roorkee. After serving U. P. State Bridge Corporation as an Assistant Engineer for more than 1 year, Rajendra Chalisgaonkar joined U.P. Irrigation Department as an Assistant Engineer in April 1981 and retired as **Engineer-in-Chief and Head of Irrigation Department, Govt. of Uttarakhand. Mr. Chalisgaonkar** was also the **Managing Director**, Uttarakhand Project Development and Construction Corporation Ltd. For more than 2 years. He was responsible for the development of Irrigation, policy making at State Level, planning of water resources and hydropower projects, and construction of infrastructure projects. He has more than 35 years of varied experience, which includes Investigation, Planning, Design, Research and CAD Applications, Construction of Water Resources/Infrastructure Projects and worked on prestige projects of Uttar Pradesh and Uttarakhand, which includes Tehri Dam, Maneri Bhali Hydroelectric Stage-II, Jamrani Dam, Song Dam, prepared Pre-Feasibility Report and Detailed Project Report for Hydropower and Water Resources Project and designed Small Hydropower Projects as Design Consultant of U. P. Micro Hydel Corporation Ltd. He has also been associated with the infrastructural restoration works after the 2013 disaster in the State. Mr. Chalisgaonkar has authored a book on Computer – Aided Concrete Mix Design, authored more than 120 research papers in various journals and symposia in India and abroad, and organised 6 Workshops/Conferences and 90 Training Courses and delivered hundreds of lectures. Post Superannuation, Mr. Chalisgaonkar has worked as Deputy Team Leader for River Morphology Project in Uttarakhand for M/S DHI (India) Water & Environment Pvt. Ltd. and Water Resources and Small Hydropower Development Consultant for HRED, IIT Roorkee. Mr. Chalisgaonkar has been Life Fellow of many professional organizations including IEI, IWRS, IRC etc. He has been recipient of following prestigious awards besides other awards and honours:

- **ENGINEERING EXCELLENCE IN FIELD AWARD-2017** by Roorkee Local Centre, The Institution of Engineers (India), Roorkee.
- **EMINENT ENGINEERS AWARD-2014** for Outstanding Contribution in Design of Water Resources and Hydropower Development by The Institution of Engineers (India), Uttarakhand State Centre, Dehradun.
- **CBIP YOUNG ENGINEERS AWARD-1992** for Notable Contribution in the field of Water Resources by Central Board of Irrigation and Power (CBIP), New Delhi.
- **HYDROSEM AWARD-1996** for Outstanding Contribution in Hydropower Development by The Institution of Engineers (India), U.P. State Centre, Lucknow.
- **D.B. ANAND MEDAL-1992** for Best Research Paper on Concrete Technology by Central Board of Irrigation and Power (CBIP), New Delhi.
- **GWALIOR RATNA-1997** by Indian Junior Chamber, Gwalior Division in recognition of outstanding ability, accomplishment and service to the Community.

Section III - Evaluation and Qualification Criteria

This section contains all the criteria that the Employer shall use to evaluate bids and qualify Bidders if the bidding was not preceded by a prequalification exercise and post qualification is applied. In accordance with ITB 32 and ITB 35, no other methods, criteria and factors shall be used. The Bidder shall provide all the information requested in the forms included in Section IV (Bidding Forms).

1. Technical Part

1.1 Adequacy of Technical Proposal

Evaluation of the Bidder's Technical Proposal will include:

- (i) an assessment of the Bidder's technical capacity to mobilize key equipment and personnel for the contract consistent with its proposal regarding work methods, scheduling, material sourcing and Quality Control/Assurance in sufficient detail and fully in accordance with the requirements stipulated in Section VII (Works Requirements).

For this purpose, the Bidder should also submit:

A detailed note outlining its proposed methodology and program of construction including implementation of the Environmental Management Plan, and safety Assurance under the contract backed with equipment planning and deployment, materials and manpower planning and deployment, duly supported with broad calculations and quality control system/assurance procedures proposed to be adopted, justifying their capability of execution and completion of the work as per technical specifications within the stipulated period of completion as per milestones.

- (ii) an assessment of the details of subcontracting elements of works amounting to more than 10% of the bid price; for each element proposed to be sub contracted furnish details whether the identified Sub-contractor possesses the required qualifications and experiences to execute that element satisfactorily. [***Work should not be split into small parts and sub-contracted***].

1.2 Multiple Contracts if permitted: (NOT PERMITTED)

1.3 Specialised Subcontractors: NA

2. Qualification

Eligibility and Qualification Criteria			Compliance Requirements				Documentation
No.	Subject	Requirement	Single Entity	Joint Venture where permitted			Submission Requirements
				All Parties Combined	Each Member	One Member	

2.1 Eligibility

2.1.1	Nationality	Nationality in accordance with ITB Sub-Clause 4.3.	Must meet requirement	Must meet requirement	N / A	N / A	Forms ELI -1.1 and ELI-1.2 With attachments/ documents
2.1.2	Conflict of Interest	No conflicts of interest in ITB Sub-Clause 4.2.	Must meet requirement	Must meet requirement	N / A	N / A	Letter of Bid
2.1.3	Bank eligibility	Not having been declared ineligible by the Bank, as described in ITB Sub-Clause 4.4. & 4.7.	Must meet requirement	Must meet requirement	N / A	N / A	Letter of Bid
2.1.4	Government Owned Entity	Bidder to meet conditions of ITB Sub-Clause 4.5. The entity should not be a dependent agency of the borrower or sub-borrower or Employer.	Must meet requirement	Must meet requirement	N / A	N / A	Forms ELI -1.1 and 1.2 with attachments/ documents
2.1.5	United Nations resolution or Borrower's country law	Not having been excluded as a result of prohibition in the Borrower's country laws or official regulations against commercial relations with the Bidder's country, or by an act of compliance with UN Security Council resolution, both in accordance with ITB 4.7 and Section V.	Must meet requirement	Must meet requirement	N / A	N / A	Forms ELI -1.1 and 1.2 with attachments/ documents

Eligibility and Qualification Criteria			Compliance Requirements			Documentation	
No.	Subject	Requirement	Single Entity	Joint Venture where permitted			Submission Requirements
				All Parties Combined	Each Member	One Member	

2.2 Historical Contract Non-Performance

2.2.1	History of Non-Performing Contracts	Non-performance of a contract ² did not occur as a result of contractor default since 1 st March 2014	Must meet requirement by itself or as member to past or existing JV	Must meet requirement by itself or as member to past or existing JV	N / A	N / A	Form CON - 2
2.2.2	Suspension due to withdrawal of the Bid within Bid validity	Not under suspension due to withdrawal of the Bid pursuant ITB 19.6.	Must meet requirement	Must meet requirement	N/A	N/A	Letter of Bid
2.2.3	Pending Litigation	Bidder's financial position and prospective long-term profitability sound according to criteria established in 2.3.1 below and assuming that all pending litigation will be resolved against the Bidder	Must meet requirement by itself or as member to past or existing JV	Must meet requirement by itself or as member to past or existing JV	N / A	N / A	Form CON - 2

² Non-performance, as decided by the Employer, shall include all contracts where (a) nonperformance was not challenged by the contractor, including through referral to the dispute resolution mechanism under the respective contract, and (b) contracts that were so challenged but fully settled against the contractor. Non-performance shall not include contracts where Employers decision was overruled by the dispute resolution mechanism. Non-performance must be based on all information on fully settled disputes or litigation, i.e. dispute or litigation that has been resolved in accordance with the dispute resolution mechanism under the respective contract and where all appeal instances available to the Bidder have been exhausted.

Eligibility and Qualification Criteria			Compliance Requirements				Documentation
No.	Subject	Requirement	Single Entity	Joint Venture where permitted			Submission Requirements
				All Parties Combined	Each Member	One Member	
2.2.4	Litigation History	No consistent history of court/arbitral award decisions against the Bidder ³ since 1 st April, 2016	Must meet requirement by itself or as member to past or existing JV	Must meet requirement by itself or as member to past or existing JV	N/A	N/A	Form CON - 2
2.5	Declaration: Environmental, Social, Health, and Safety (ESHS) past performance	Declare any civil work contracts that have been suspended or terminated and/or performance security called by an employer for reasons related to the non-compliance of any environmental, or social, or health or safety requirements or regulations in the past five years ⁴ .	Must make the declaration. Where there are Specialized Sub-contractor/s, the Specialized Sub-contractor/s must also make the declaration.	Must make the declaration. Where there are Specialized Sub-contractor/s, the Specialized Sub-contractor/s must also make the declaration.		N/A	Form CON-3 ESHS Performance Declaration

³The Bidder shall provide accurate information on the letter of Bid about any litigation or arbitration resulting from contracts completed or ongoing under its execution over the last five years. A consistent history of court/arbitral awards against the Bidder or any member of a joint venture may result in disqualifying the Bidder.

⁴The Employer may use this information to seek further information or clarifications in carrying out its due diligence.

Qualification Criteria			Compliance Requirements			Documentation
No.	Subject	Requirement	Single Entity	Joint Venture where permitted		Submission Requirements
				All Parties Combined	Each Member	One Member

2.3 Financial Situation and Performance

2.3.1	Financial Capabilities	<p>(a) The Bidder shall demonstrate that it has access to, or has available, liquid assets, unencumbered real assets, lines of credit, and other financial means (independent of any contractual advance payment) sufficient to meet the construction cash flow requirements estimated as Rs. 270.06 Lakh for the subject contract(s) net of the Bidders other commitments</p> <p>(b) The Bidders shall also demonstrate, to the satisfaction of the Employer, that it has adequate sources of finance to meet the cash flow requirements on works currently in progress and for future contract commitments</p> <p>(c) The audited balance sheets or, if not required by the laws of the Bidder's country, other financial statements acceptable to the</p>	<p>(a) Must meet requirement</p> <p>(b) Must meet requirement</p> <p>(c) Must meet requirement</p>	<p>(a) Must meet requirement</p> <p>(b) Must meet requirement</p> <p>(c) Must meet requirement</p>	NA	NA	Form FIN - 3.1 with attachments
-------	------------------------	--	--	--	----	----	---------------------------------

Qualification Criteria			Compliance Requirements			Documentation	
No.	Subject	Requirement	Single Entity	Joint Venture where permitted			Submission Requirements
				All Parties Combined	Each Member	One Member	
		Employer, for the last <i>five</i> years i.e., 2016-17, 2017-18, 2018-19, 2019-20, 2020-21 shall be submitted and must demonstrate the current soundness of the Bidder's financial position and indicate its prospective long-term profitability.					
<p>NOTE: The construction cash flow requirement should be for a number of months determined as the total time needed to pay contractor invoice by the Employer. The cash flow should not normally exceed 3 months peak contract requirements and availability should be certified by Bank (Nationalized or Scheduled Bank in India) in form 3.1 A</p>							
2.3.2	Annual Construction Turnover	Achieved in at least two financial years (in the last five years) a minimum annual financial turnover ⁵ in civil engineering construction work of Rs. 270.06 Lakhs calculated as total certified payments received for contracts in progress or completed.	Must meet requirement	Must meet requirement			Form FIN - 3.2

⁵ At 2019-20 price level. Financial turnover of previous years shall be given weightage @5% per year based on rupees value to bring them to the price level of the financial year in which bids are received.

Qualification Criteria			Compliance Requirements				Documentation
No.	Subject	Requirement	Single Entity	Joint Venture where permitted			Submission Requirements
				All Parties Combined	Each Member	One Member	

2.4 Experience

2.4.1	General Construction Experience	Experience under construction contracts for similar works such as those pertaining to tube well and exploratory drilling in the role of contractor, JV member, sub-contractor, or management contractor for at least the last five [5] years prior to the bid submission deadline.	Must meet requirement	Must meet requirement	N/A	N/A	Form EXP – 4.1
2.4.2 (a)	Specific Construction Experience	<p>Bidder should have successfully competed as a prime contractor, CONSORTIUM member, management contractor or subcontractor similar works during last three years ending last day of month previous to the one in which tenders are invited:</p> <p>(a) Three similar completed works costing not less than the amount equal to 108.02 Lakh. or, (b) Two similar completed works costing not less than the amount equal to 135.03 Lakhs. or,</p>	Must meet requirement	Must meet requirement			Form EXP 4.2(a). The contractor should have borne responsibility for execution of works to the extent he claims experience. A contractor should not claim experience for the works he has never executed.

Qualification Criteria			Compliance Requirements			Documentation	
No.	Subject	Requirement	Single Entity	Joint Venture where permitted			Submission Requirements
				All Parties Combined	Each Member	One Member	
		<p>(c) One similar completed work costing not less than the amount equal to 270.06 Lakhs</p> <p>Sum total of similar completed works costing not less than the amount equal to Rs. 270.06 Lakhs in a single financial year. Construction of building works, Construction, provision for firefighting etc.</p> <p>The similarity shall be based on the physical size, complexity, methods/technology or other characteristics as described in Section VII, Employer's requirements</p>					
2.4.2 (b)	Specific Experience	<p>b) For the above or other contracts executed during the period stipulated in 2.4.2(a) above, at least in one year a minimum construction experience in the following key activities:</p> <p>Construction of Piezometers (100- 250 mm dia. more than 50 metres depth)</p> <p>Minimum nos. required- 66 nos. Construction of</p>	Must meet requirements	Must meet requirements			Form EXP-4.2(b)

Qualification Criteria			Compliance Requirements			Documentation	
No.	Subject	Requirement	Single Entity	Joint Venture where permitted			Submission Requirements
				All Parties Combined	Each Member	One Member	
		Piezometers (100- 250 mm dia. more than 50 metres depth) Minimum nos. required- 66 nos. Experience in Aquifer mapping will be considered if Drilling/ Completion of Borewell/ Tubewell would have been executed by bidder.					

Qualification Criteria			Compliance Requirements			Documentation	
No.	Subject	Requirement	Single Entity	Joint Venture where permitted			Submission Requirements
				All Parties Combined	Each Member	One Member	
2.4.2(c) Not Applicable (NA)							
2.4.2 (d)	<p>Bidders who meet the minimum qualification criteria will be qualified only if their available bid capacity for construction work is equal to or more than the total bid value of the work. The available bid capacity will be calculated as under: Assessed Available bid capacity = (A*N*1.5-B) Where, A = Maximum value of civil engineering works executed in any one year during the last five years (updated to the price level of the financial year at the rate of 5% per year), taking into account the completed as well as works in progress). N = Number of years prescribed for completion of the works for which bids are invited (period upto 6 months to be taken as half-year and more than 6 months as one year). B = Value, at the current price level, of existing commitments on-going works to be completed during the period of completion of the works for which bids are invited. Note: <i>the statements in Section IV showing the value of existing commitments of on-going works as well as the stipulated period of completion remaining for each of the works listed should be countersigned by the Engineer in charge, not below the rank of an Executive Engineer or equivalent.</i></p>						
2.4.2 (e)	<p>Even though the bidders may meet the above qualifying criteria, they are subject to be disqualified if they have: -</p> <ul style="list-style-type: none"> - made misleading or false representations in the forms, statements, affidavits, and attachments submitted in proof of the qualification requirement; - record of poor performance such as abandoning the works, not properly completion or financial failures etc. - consistent history of litigation or arbitration awards against the bidder or any member or the joint venture. - Participated in the previous bidding (if this is a re-bidding) for the same work and had quoted unreasonably high bid price and could not furnish any rational justification for the same to the Employer. 						

2.5 Personnel

The Bidder must demonstrate that it will have the personnel for the key positions that meet the following requirements:

S. No.	Designation of Personnel (Position)	No.	Minimum Qualification	Minimum years of experience	Minimum experience in similar works.	Remark
1.	Work Manager	1	B.E. (Mech./Civil) /Diploma	05	03	-
2.	Site Supervisor	1	Diploma /ITI	03	01	-
3.	Driller	1	Diploma /ITI	03	01	-
4.	Machine Technician	1	Diploma /ITI	03	01	The duty and responsibility of the Machine Technician may be carried out by the Site Supervisor provided the Site Supervisor possess Diploma in Mechanical.
5.	Environment, Health and Safety Engineer	1	Graduate in Civil or Environmental Engineering with specialization and/or additional qualification in Occupational Health and Safety.	03	01	-

The Bidder must not have in his employment:

- [i] the near relations (defined as first blood relations, and their spouses, of the bidder or the bidder's spouse) of persons of the Irrigation Department, Uttarakhand.
- [ii] without Government permission, any person who retired as gazetted officer within the last two years.

Note: The Bidder shall provide details of the proposed personnel and their experience records in the relevant Forms included in Section IV, Bidding Forms.

2.6 Equipment

The Bidder must demonstrate that it will have access to the key Contractor's equipment listed hereafter:

No.	Equipment Type and Characteristics	Capacity	Minimum Number required
1	DTH/Direct Rotary Rig with Rock Rollers and Reverse Rotary rig with Heavy duty Mud Pump With all accessories	To construct the Piezometers up to 150 mt	02
2	Air Compressor of Capacity 500-550 CFM Working at 150PSI, With all accessories	To clean each aquifer of piezometer / borewell up to 150 mt. depth with all necessary reduction pipes, airlines & accessories required	02
3	Welding Generator Set with all accessories	To weld the 6 mm. thick 150 mm. length, 75 mm. wide stiffeners between 2 joints of 6 mm thick 150 mm. dia pipes	02
4	Truck of 10 to 12 ton capacity	Capacity to carry pipes & all accessories in remote areas of Villages listed under the description of work	02
5	DTH percussion Rig with Heavy duty Compressor of 150 PSI capacity with all accessories.		02
6	All Ancillary equipment needed For Providing strong Protection Cover with civil works		02
7	Water Tanker of Minimum 5000 litre capacity		02

NOTE: The Bidder shall provide further details of proposed items of equipment using the relevant Form in Section IV.

2. Financial Part

2.1 Multiple Contracts if permitted under ITB 35.3, will be evaluated as under: NA

2.2 Other Criteria (if permitted under ITB 35.1 (f))

In addition to the criteria listed in ITB 35.1 (a) – (e) the following criteria shall apply: NA

Section IV - Bidding Forms

Letter of Bid – Technical Part

The Bidder must prepare the Letter of Bid on stationery with its letterhead clearly showing the Bidder's complete name and address.

Note: All italicized text is for use in preparing these forms and shall be deleted from the final products.

Date: _____

Invitation for Bid No.: _____

To: *(Insert name of the Employer)*

We, the undersigned, hereby submit our bid, in two parts, namely:

- (a) the Technical Part, and
- (b) the Financial Part

In submitting our Bid, we make the following declarations:

- (a) We have examined and have no reservations to the Bidding Documents, including Addenda issued in accordance with Instructions to Bidders (ITB8);
- (b) We meet the eligibility requirements and have no conflict of interest in accordance with ITB 4;
- (c) We offer to execute in conformity with the Bidding Documents the following Works:

—;

- (d) Our bid shall be valid for a period of _____ *[insert validity period as specified in ITB 18.1.]* days from the date fixed for the bid submission deadline in accordance with the Bidding Documents, and it shall remain binding upon us and may be accepted at any time before the expiration of that period;
- (e) We accept the appointment of *[insert name proposed in Bid Data Sheet]* as the Adjudicator/Dispute Review Expert

[or]

We do not accept the appoint of *[insert name proposed in Bid Data Sheet]* as he Adjudicator/Dispute Review Expert, and propose instead that *[insert name]* be

-
- appointed⁸ as Adjudicator/Dispute Review Expert, whose daily fees and biographical data are attached;
- (f) If our bid is accepted, we commit to obtain a performance security in accordance with the Bidding Document;
 - (g) We are not participating, as a Bidder, in more than one bid in this bidding process in accordance with ITB 4.2,
 - (h) Our firm, its affiliates or subsidiaries, including any Subcontractors or Suppliers for any part of the contract, has not been declared ineligible by the Bank, under the Employer's country laws or official regulations or by an act of compliance with a decision of the United Nations Security Council(ITB 4.7);
 - (i) We are not a government owned entity / We are a government owned entity but meet the requirements of ITB 4.5⁹;
 - (j) We hereby certify that we have taken steps to ensure that no person acting for us or on our behalf will engage in any type of fraud and corruption.
 - (k) We also undertake that, in competing for (and, if the award is made to us, in executing) the above contract, we will strictly observe the laws against fraud and corruption in force in India on date namely "Prevention of Corruption Act 1988."
 - (l) We understand that this bid, together with your written acceptance thereof included in your notification of award, shall constitute a binding contract between us, until a formal contract is prepared and executed;
 - (m) We understand that you are not bound to accept the lowest evaluated bid or any other bid that you may receive; and
 - (n) If awarded the contract, the person named below shall act as Contractor's Representative:
-

Name of the Bidder* ***[insert complete name of person signing the Bid]***

Name of the person duly authorized to sign the Bid on behalf of the Bidder** ***[insert complete name of person duly authorized to sign the Bid]***

Title of the person signing the Bid ***[insert complete title of the person signing the Bid]***

Signature of the person named above ***[insert signature of person]***

⁸In case appointment of Adjudicator was proposed from the list provided by an Institution in ITB 46, the replacement should also be proposed from the list of same institution.

⁹Use one of the two options as appropriate.

whose name and capacity are shown above]

Date signed *[insert date of signing]* day of *[insert month]*, *[insert year]*

*: In the case of the Bid submitted by joint venture specify the name of the Joint Venture as Bidder

** : Person signing the Bid shall have the power of attorney given by the Bidder to be attached with the Bid Schedules.

.....
.....

Technical Proposal

Technical Proposal Forms

- **Site Organization**
- **Method Statement**
- **Mobilization Schedule**
- **Construction Schedule**
- **ESHS Management Strategies and Implementation Plans**
- **Code of Conduct (ESHS)**
- **Equipment**
- **Personnel**
- *Note: Work should not be split into small parts and sub-contracted; but sub-contracting specialized elements of works is acceptable.*
- **Others**
- *Form of Bid Security - Bank Guarantee*

Appendix to Technical Part
Technical Proposal – Site Organization

[Insert Site Organization information]

Technical Proposal – Method Statement

[insert method Statement – A detailed note should be submitted outlining bidders proposed methodology and program of construction including Environmental Management Plan, backed with equipment, materials and manpower planning and deployment, duly supported with broad calculations and quality control system/assurance procedures proposed to be adopted, justifying their capability of execution and completion of the work as per technical specifications within the stipulated review of completion as per mile stones]

Technical Proposal – Mobilization Schedule

[Insert Mobilization Schedule]

Technical Proposal – Construction Schedule

Drilling and installation of 66 nos. groundwater monitoring wells and construction of 66 nos. Protection works for DWLR telemetry system to monitor groundwater level and quality under National Hydrology Project (NHP)				
Tentative timeline for the execution of project				
	Months	<i>1-3</i>	<i>4-6</i>	<i>7-9</i>
Sl. No.	Milestone			
1	Drilling and installation of 22nos. groundwater monitoring wells and construction of 22 nos. Protection works	<i>3Month</i>		
2	Drilling and installation of 22nos. groundwater monitoring wells and construction of 22 nos. Protection works		<i>3Month</i>	
3	Drilling and installation of 22nos. groundwater monitoring wells and construction of 22 nos. Protection works			<i>3Month</i>

Technical Proposal – Sub Contracting-NA

[Insert proposal of sub-contracting elements of works amounting to more than 10% of the bid price for each element and indicate the name of the sub-contractor, its qualifications and experiences to execute that element satisfactorily]

Appendix to Technical Part

ESHS Management Strategies and Implementation Plans

(ESHS-MSIP)

[Note to Employer: modify the text in italics in the numbered points below, to name the appropriate documents.]

The Bidder shall submit comprehensive and concise Environmental, Social, Health and Safety Management Strategies and Implementation Plans (ESHS-MSIP) as required by ITB 11.2 (j) of the Bid Data Sheet. These strategies and plans shall describe in detail the actions, materials, equipment, management processes etc. that will be implemented by the Contractor, and its subcontractors.

In developing these strategies and plans, the Bidder shall have regard to the ESHS provisions of the contract including those as may be more fully described in the following:

1. *[the Works Requirements described in Section VII];*
2. *[Environmental and Social Impact Assessment (ESIA)];*
3. *[Environmental and Social Management Plan (ESMP)];*
4. *[Resettlement Action Plan (RAP)];*
5. *[Consent Conditions (regulatory authority conditions attached to any permits or approvals for the project)]; and*
6. *[specify any other relevant document/s]*

Code of Conduct: Environmental, Social, Health and Safety (ESHS)

[Note to Employer: modify the text in italics in the numbered points below, to name the appropriate documents.]

The Bidder shall submit the Code of Conduct that will apply to the Contractor's employees and subcontractors as required by ITB 11.2 (j) of the Bid Data Sheet. The Code of Conduct shall ensure compliance with the ESHS provisions of the contract, including those as may be more fully described in the following:

1. *[the Works Requirements described in Section VII];*
2. *[Environmental and Social Impact Assessment (ESIA)];*
3. *[Environmental and Social Management Plan (ESMP)];*
4. *[Consent Conditions (regulatory authority conditions attached to any permits or approvals for the project)]; and*
5. *[specify any other relevant document/s]*

In addition, the Bidder shall submit an outline of how this Code of Conduct will be implemented. This will include: how it will be introduced into conditions of employment/engagement, what training will be provided, how it will be monitored and how the Contractor proposes to deal with any breaches.

Appendix to Technical Part

Forms for Personnel

Form PER – 1: Proposed Personnel

Bidders should provide the names of suitably qualified personnel to meet the specified requirements for each of the positions listed in Section III (Evaluation and Qualification Criteria). The data on their experience should be supplied using the Form below for each candidate.

S. No.	Position	Name	Qualification	Years of Experience	Years of Experience in proposed position			
					Road * works	Building* works	Others*	Total

(* Modify this as appropriate to suit the works for which bids are invited).

Appendix to Technical Part

Form PER – 2: Resume of Proposed Personnel

The Bidder shall provide all the information requested below. Fields with asterisk (*) shall be used for evaluation.

Position*		
Personnel information	Name *	Date of birth
	Professional qualifications	
Present employment	Name of Employer	
	Address of Employer	
	Telephone	Contact (manager / personnel officer)
	Fax	E-mail
	Job title	Years with present Employer

Summarize professional experience in reverse chronological order. Indicate particular technical and managerial experience relevant to the project.

From*	To*	Company, Project, Position, and Relevant Technical and Management Experience*

Appendix to Technical Part

Form for Equipment

The bidder shall provide adequate information to demonstrate clearly that it has the capability to meet the requirements for the key equipment listed in Section III (Evaluation and Qualification Criteria). The Bidder shall provide all the information requested below.

S. No	Item of Equipment	Description	Make	Capacity	Age (years)	Condition	No. available and present location	Owned	Leased	Purchased

Appendix to Technical Part
Form SC-Sub Contracting- NA

SCHEDULE OF SUBCONTRACTORS

Item	Element of work	Approximate value of sub-contract	% of bid price	Name and address of sub-contractor	Qualification and experience of sub-contractor on similar works of the elements executed

The Bidder shall enter in this schedule a list of the major sections and appropriate value of the work for which he proposes to use subcontractors [for those costing more than 10% of the bid price for each element], together with the names, addresses and experiences of the proposed subcontractors.

The capability of the sub-contractor will also be assessed (on the same lines as for the main Contractor) before according approval to him.

(Work should not be split into small parts and sub-contracted; but, sub-contracting specialized elements of works is acceptable).

Appendix to Technical Part

Bidder's Qualification

To establish its qualifications to perform the contract in accordance with Section III (Evaluation and Qualification Criteria) the Bidder shall provide the information requested in the corresponding Information Sheets included hereunder

Appendix to Technical Part

Form-ELI -1.1: Bidder Information Form

Date: *[insert day, month, year]*

NCB No. and title: *[insert NCB number and title]*

Page *[insert page number]* of *[insert total number]* pages

1.1 Bidder Information			
Bidder's legal name			
In case of JV, legal name of each member			
Bidder's country of constitution			
Bidder's year of constitution			
Bidder's legal address in country of constitution			
Bidder's authorized representative (name, address, telephone numbers, fax numbers, e-mail address)			
Attached are copies of the following original documents.			
<ol style="list-style-type: none"> 1. In case of single entity, articles of incorporation or constitution of the legal entity names above, in accordance with ITB 4.1.1 and 4.3. 2. Authorization to represent the firm or JV named in above, in accordance with ITB 20.2. 3. In case of JV, letter of intent to form JV or JV agreement: in accordance with ITB 4.1.2 read with BDS 4. In case of government-owned entity, documents establishing legal and financial authority and compliance with the principles of commercial law in accordance with ITB 4.5 read with Sub-clause 2.1.4 of Qualification Criteria. 5. Included are the organizational chart, a list of Board of Directors, and the beneficial ownership. 			

Appendix to Technical Part

Form-ELI -1.2: JV Information Form

N/A

(Where permitted as per BDS ITB 4.1.1)

Each member of a JV must fill in this form

Date: [insert day, month, year]

NCB No. and title: [insert NCB number and title]

Page [insert page number] of [insert total number] pages

JV/Specialist Subcontractor Information			
Bidder's legal name			
JV Member's or Subcontractor's legal name			
JV Member's or Subcontractor's country of constitution			
JV Member's or Subcontractor's year of constitution			
JV Member's or Subcontractor's legal address in country of constitution			
JV Member's or Subcontractor's authorized representative information (name, address, telephone numbers, fax numbers, e-mail address)			
<p>Attached are copies of the following original documents.</p> <ol style="list-style-type: none"> 1. Articles of incorporation or constitution of the legal entity named above, in accordance with ITB 4.1.1 read with BDS and ITB 4.1.2. 2. Authorization to represent the firm names above, in accordance with ITB 20.2. 3. In the case of government-owned entity, documents establishing legal and financial autonomy and compliance with commercial law, in accordance with ITB Sub-Clause 4.5 read with Sub-Clause 2.1.4 of Qualification Criteria. 4. Included are the organizational chart, a list of Board of Directors, and the beneficial ownership. 			

Appendix to Technical Part

DETAILS OF PARTICIPATION IN THE JOINT VENTURE

N/A

PARTICIPATION DETAILS	FIRM 'A' (Lead Member)	FIRM 'B'	FIRM 'C'
Financial			
Name of the Banker(s)			
Planning			
Construction Equipment			
Key Personnel			
Execution of Work (Give details on proposed contribution of each)			

The Joint Venture should indicate the details of participation as above.

Appendix to Technical Part
Form CON – 2
Historical Contract Non-Performance, Pending Litigation and
Litigation History

[The following table shall be filled in for the Bidder and for each member of a Joint Venture]

Bidder's Name: [insert full name] Date: [insert day, month, year]
Joint Venture Party Name: [insert full name]
NCB No. and title: [insert NCB number and title]
Page [insert page number] of [insert total number] pages

Non-Performed Contracts in accordance with Section III, Qualification Criteria and Requirements			
<input type="checkbox"/> Contract non-performance did not occur during the <i>(number)</i> years specified in Section III, Qualification Criteria and Requirements, Sub-Factor 2.2.1.			
<input type="checkbox"/> Contract(s) not performed during the <i>(number)</i> of years specified in Section III, Qualification Criteria and Requirements, requirement 2.2.1			
Year	Non-performed portion of contract	Contract Identification	Total Contract Amount (in Indian Rupees)
<i>[insert year]</i>	<i>[insert amount and percentage]</i>	Contract Identification: <i>[indicate complete contract name/ number, and any other identification]</i> Name of Employer: <i>[insert full name]</i> Address of Employer: <i>[insert street/city/country]</i> Reason(s) for non-performance: <i>[indicate main reason(s)]</i>	<i>[insert amount]</i>
Pending Litigation, in accordance with Section III, Qualification Criteria and Requirements			
<input type="checkbox"/> No pending litigation in accordance with Section III, Qualification Criteria and Requirements, Sub-Factor 2.2.3.			
<input type="checkbox"/> Pending litigation in accordance with Section III, Qualification Criteria and Requirements, Sub-Factor 2.2.3 as indicated below.			

Year of dispute	Amount in dispute (Rupees)	Contract Identification	Total Contract Amount (Rupees)
<i>[insert year]</i>	<i>[insert amount]</i>	Contract Identification: [indicate complete contract name, number, and any other identification] Name of Employer: <i>[insert full name]</i> Address of Employer: <i>[insert street/city/country]</i> Matter in dispute: <i>[indicate main issues in dispute]</i> Party who initiated the dispute: <i>[indicate "Employer" or "Contractor"]</i> Status of dispute: <i>[Indicate if it is being treated by the Adjudicator, under Arbitration or being dealt with by the Judiciary]</i>	<i>[insert amount]</i>
<input type="checkbox"/> No pending litigation in accordance with Section III, Qualification Criteria and Requirements, Sub-Factor 2.2.3. <input type="checkbox"/> Pending litigation in accordance with Section III, Qualification Criteria and Requirements, Sub-Factor 2.2.3 as indicated below.			
Year of award	Outcome as percentage of Net Worth	Contract Identification	Total Contract Amount (Rupees)
<i>[insert year]</i>	<i>[insert percentage]</i>	Contract Identification: [indicate complete contract name, number, and any other identification] Name of Employer: <i>[insert full name]</i> Address of Employer: <i>[insert street/city/country]</i> Matter in dispute: <i>[indicate main issues in dispute]</i> Party who initiated the dispute: <i>[indicate "Employer" or "Contractor"]</i> Status of dispute: <i>[Indicate if it is being treated by the Adjudicator, under Arbitration or being dealt with by the Judiciary]</i>	<i>[insert amount]</i>

Appendix to Technical Part

Form CON – 3: ESHS Performance Declaration

[The following table shall be filled in for the Bidder, each member of a Joint Venture and each Specialized Subcontractor]

Bidder's Name: *[insert full name]*

Date: *[insert day, month, year]*

Joint Venture Member's or Specialized Subcontractor's Name: *[insert full name]*

RFB No. and title: *[insert RFB number and title]*

Page *[insert page number]* of *[insert total number]* pages

Environmental, Social, Health, and Safety Performance Declaration in accordance with Section III, Qualification Criteria, and Requirements			
<input type="checkbox"/> No suspension or termination of contract: An employer has not suspended or terminated a contract and/or called the performance security for a contract for reasons related to Environmental, Social, Health, or Safety (ESHS) performance since the date specified in Section III, Qualification Criteria, and Requirements, Sub-Factor 2.5.			
<input type="checkbox"/> Declaration of suspension or termination of contract: The following contract(s) has/have been suspended or terminated and/or Performance Security called by an employer(s) for reasons related to Environmental, Social, Health, or Safety (ESHS) performance since the date specified in Section III, Qualification Criteria, and Requirements, Sub-Factor 2.5. Details are described below:			
Year	Suspended or terminated portion of contract	Contract Identification	Total Contract Amount (current value, currency, exchange rate and US\$ equivalent)
<i>[insert year]</i>	<i>[insert amount and percentage]</i>	Contract Identification: <i>[indicate complete contract name/ number, and any other identification]</i> Name of Employer: <i>[insert full name]</i> Address of Employer: <i>[insert street/city/country]</i> Reason(s) for suspension or termination: <i>[indicate main reason(s)]</i>	<i>[insert amount]</i>
<i>[insert year]</i>	<i>[insert amount and percentage]</i>	Contract Identification: <i>[indicate complete contract name/ number, and any other identification]</i>	<i>[insert amount]</i>

	Name of Employer: <i>[insert full name]</i> Address of Employer: <i>[insert street/city/country]</i> Reason(s) for suspension or termination: <i>[indicate main reason(s)]</i>	
...	<i>[list all applicable contracts]</i>	...
Performance Security called by an employer(s) for reasons related to ESHS performance		
Year	Contract Identification	Total Contract Amount (current value, currency, exchange rate and US\$ equivalent)
<i>[insert year]</i>	Contract Identification: <i>[indicate complete contract name/ number, and any other identification]</i> Name of Employer: <i>[insert full name]</i> Address of Employer: <i>[insert street/city/country]</i> Reason(s) for calling of performance security: <i>[indicate main reason(s)]</i>	<i>[insert amount]</i>

Appendix to Technical Part Financial Situation

FORMAT 3.1 Historical Financial Performances

Bidder's Legal Name: _____

Date: _____

Bidding No.: _____

Page _____ of _____ pages

GST Registration no:

PAN:

To be completed by the Bidder

SUMMARY OF FINANCIAL STATEMENTS							
Name of bidder:							
(Equivalent Rs. Million)							
S. No.	Financial Information in Rupee equivalent with exchange rate at the end of concerned year	Actuals for Previous five years excluding the current financial year					Ref. of Page Nos. of Balance Sheets
(1)	(2)	(3)	(4)	(5)	(6)	(7)	(8)
1.	Total Assets						
2.	Total Turnover						
3.	Current Assets						
4.	Current Assets + Loan & Advances						
5.	Total Liabilities						
6.	Current Liabilities						
7.	Current liabilities & provision						
8.	Profit before Interest and Tax						
9.	Profit before Tax						
10.	Profit after Tax						
11.	Shareholder's Funds (Net Worth)=(Paid up equity +Reserves)-(revaluation reserves + Miscellaneous expenditure not written off) Depreciation						
12.	Current Ration (2)/(5)						
13.	Net cash accruals= Profit after Tax + depreciation						
14.							

This information should be extracted from the Annual Financial Statements/ Balance sheets, which should be enclosed. Year 1 will be the latest year for which audited financial statements are available. Year 2 shall be the year immediately preceding year 1 and year 3 shall be the year immediately preceding Year 2.

2. Financial documents

The Bidder and its parties shall provide copies of the balance sheets and/or financial statements for *[number]* years pursuant Section III, Qualifications Criteria and Requirements, Sub-factor 2.3.1. The financial statements shall:

- (a) reflect the financial situation of the *Bidder* or member to a JV, and not sister or parent companies.
 - 1. (b) be audited by a certified Chartered Accountant.
 - 2. (c) be complete, including all notes to the financial statements.
- (d) Correspond to accounting periods already completed and audited (no statements for partial periods shall be requested or accepted).
 - Attached are copies of financial statements (balance sheets, including all related notes, and income statements) for the *[number]* years required above; and complying with the requirements (If the most recent set of financial statements is for a period earlier than 12 months from the date of bid, the reason for this should be justified)
 - Attached is a copy of certificate given from the commercial bank assuring cash flow (working capital for contraction) in the format attached.

Appendix to Technical Part
FORM FIN – 3.1(A)

**FORMAT FOR EVIDENCE OF ACCESS TO OR AVAILABILITY OF CASH
FLOW**

[To be given from a Nationalized or Scheduled Bank in India-No substitute other than this
will be acceptable]

Clause 2.3.1(b) of Section II – Qualification Criteria

(1) AVAILABILITY OF CASH FLOW (WORKING CAPITAL)

This is to certify that M/s. _____ is a reputed company
with a good financial standing.

If the contract for the works, namely _____
[funded by the World Bank] is awarded to the above firm, we shall be able to provide
overdraft/credit facilities to the extent of Rs. _____ to meet their capital requirements
for executing the above contract.

-- Sd. --

Manager

Name of Bank

Senior Bank Manager

Address of the Bank

Appendix to Technical Part

Form FIN - 3.2

Annual Construction Turnover

[The following table shall be filled in for the Bidder and for each member of a Joint Venture]

Bidder's/Joint Venture Member's Legal Name: *[insert full name]*

Date: *[insert day, month, year]*

JV Party Legal Name: *[insert full name]*

NCB No. and title: *[insert NCB number and title]*

Page *[insert page number]* of *[insert total number]* pages

Annual turnover data (construction only)*		
Year	Amount in Rupees	
<i>[indicate year]</i>	<i>[insert amount]</i>	

* **Annual construction turnover calculated as total certified payments received for work in progress or completed, for 5 years. Specified in Section III, Qualification Criteria and Requirements, Sub-Factor 2.3.2. This should be certified by a Chartered Accountant.**

Page ...of.....Pages

**Appendix to Technical Part
Form EXP - 4.1
General Construction Experience**

[The following table shall be filled in for the Bidder and for each member of a Joint Venture]

*Bidder's/Joint Venture Member's Legal Name: [insert full name]
Date: [insert day, month, year]
JV Party Legal Name: [insert full name]
NCB No. and title: [insert NCB number]
Page [insert page number] of [insert total number]pages*

[Identify contracts that demonstrate continuous construction work over the past [5] years pursuant to Section III, Qualification Criteria and Requirements, Sub-Factor 2.4.1. List contracts chronologically, according to their commencement (starting) dates.]

Starting Month / Year	Ending Month / Year	Contract Identification	Role of Bidder
<i>[indicate month/year]</i>	<i>[indicate month/year]</i>	<i>Contract name: [insert full name] Brief Description of the Works performed by the Bidder: [describe works performed briefly] Amount of contract: [insert amount in Rupees] Name of Employer: [indicate full name] Address: [indicate street/number/town or city/country]</i>	<i>[insert "Contractor" or "Subcontractor" or "Contract Manager"]</i>
		<i>Contract name: [insert full name] Brief Description of the Works performed by the Bidder: [describe works performed briefly] Amount of contract: [insert amount in Rupees] Name of Employer: [indicate full name] Address: [indicate street/number/town or city/country]</i>	<i>[insert "Contractor" or "Subcontractor" or "Contract Manager"]</i>
		<i>Contract name: [insert full name] Brief Description of the Works performed by the Bidder: [describe works performed briefly] Amount of contract: [insert amount in Rupees] Name of Employer: [indicate full name] Address: [indicate street/number/town or city/country]</i>	<i>[insert "Contractor" or "Subcontractor" or "Contract Manager"]</i>

Appendix to Technical Part

Form EXP - 4.2(a) Similar Construction Experience

[The following table shall be filled in for contracts performed by the Bidder,]

Bidder's/ Legal Name: [insert full name]

Date: [insert day, month, year]

NCB No. and title: [insert NCB number and title]

Page [insert page number] of [insert total number] pages

(A) Work performed as prime Contractor or Sub-Contractor or Management Contractor *(in the same name and style)* on construction works of a similar nature and volume over the last five years. *[Attach certificate from the Engineer-in-charge.]*

Project Name	Name of Employer	Description of work	Contract No.	Value of contract	Date of Issue of Work Order	Stipulated Date of Completion	Actual Date of Completion	Remarks explaining reasons for Delay, if any

**Appendix to Technical Part
Form EXP - 4.2(b)
Construction Experience in Key Activities**

Bidder's Legal Name: *[insert full name]* Date: *[insert day, month, year]*

JV Party Name: [insert full name]

Nominated Sub-contractor's Legal Name¹⁰

NCB No. and title: [insert NCB number and title]

Page [insert page number] of [insert total number] pages

(B) Quantities of work executed as prime contractor or Sub-Contractor (in the same name and style) in the last five years:¹¹

Year	Name of the Work	Name of the Employer *	Quantity of Work performed (cum) @				Remarks * (indicate contract agreement Ref for each year)
			Cement Concrete	Masonry	Earth Work	Piling	
2015-16							
2016-17							
2017-18							
2018-19							
2019-20							

@ the items or work for which date is requested should tally with that specified in Qualification Criteria

*** Attach certificates from Engineer in-charge**

¹⁰ If applicable

¹¹ Immediately preceding the financial year in which bids are received.

Appendix to Technical Part

Form for Current Contract Commitments/Works in Progress

Bidders and each member to a JV should provide information on their current commitments on all contracts that have been awarded, or for which a letter of intent or acceptance has been received, or for contracts approaching completion, but for which an unqualified, full completion certificate has yet to be issued.

(A) Existing commitments and on-going works:

Description of Work	Place & State	Contract No. & Date	Name and Address of Employer	Value of Contract (Rupees)	Stipulated period of completion	Value of works* remaining to be completed (Rupees)	Anticipated date of completion
(1)	(2)	(3)	(4)	(5)	(6)	(7)	(8)

(B) Works for which bids already submitted and likely to be awarded – expected additional commitment.

Description of Work	Place & State	Name and Address of Employer	Estimated value of works (Rupees)	Stipulated period of completion	Date when decision is expected	Remarks if any
(1)	(2)	(3)	(4)	(5)	(6)	(7)

* Attach certificate(s) from the Engineer(s)-in-Charge.

Appendix to Technical Part

(Name of the Project)

(Declaration regarding customs/ excise duty exemption for materials/construction equipment bought for the work)

(Bidder's Name and Address)

To:
(Name of the
Employer & address)

Dear Sir:

Re: [Name of Work].....

Certificate for Import/Procurement of Goods/Construction Equipment

1. We confirm that we are solely responsible for obtaining customs/excise duty waivers which we have considered in our bid and in case of failure to receive such waivers for reasons whatsoever, the Employer will not compensate us.
2. We are furnishing below the information required by the Employer for issue of the necessary certificates in terms of the Government of India Central Excise Notification No.108/95 read alongwith all subsequent amendments including the amendment dated 01-03-2008 and Customs Notification No. 85/99.
3. The goods/construction equipment for which certificates are required are as under:

Items (modify the list suitably for each specific work)	Make/ Brand Name	Capacity [where applicable]	Quantity	Value	State whether it will be procured locally or imported [if so from which country]	Remarks regarding justification for the quantity and their usage in works.
Goods						
Construction Equipment						

4. We agree that no modification to the above list is permitted after bids are opened.

-
5. We agree that the certificate will be issued only to the extent considered reasonable by the Employer for the work, based on the Bill of Quantities and the construction program and methodology as furnished by us alongwith the bid.

 6. We confirm that the above goods and construction equipment will be exclusively used for the construction of the above work and the construction equipment will not be sold or otherwise disposed of in any manner for a period of five years from the date of acquisition.

Date: _____

(Signature) _____

Place: _____

(Printed Name) _____

(Designation) _____

(Common Seal)

[This certificate will be issued within 60 days of signing of contract and no subsequent changes will be permitted.]

**** Modify the above to suit the requirements given in Central Excise/Customs Notification as current of date of bidding.***

Appendix to Technical Part

Form of Bid Security - Bank Guarantee

[Guarantor letterhead or SWIFT identifier code]

Bid Guarantee No..... [insert guarantee reference number]

Date..... [insert date of issue of the guarantee]

WHEREAS, _____ [name of Bidder]¹² (hereinafter called "the Bidder") has submitted his Bid dated _____ [date] or will submit his Bid for the construction of _____ [name of Contract] (hereinafter called "the Bid") under Invitations for Bids No.....[insert number] (hereinafter called "the IFB")

KNOW ALL PEOPLE by these presents that We _____ [name of bank] of _____ [name of country] having our registered office at _____ (hereinafter called "the Bank") are bound unto _____ [name of Employer] (hereinafter called "the Employer") in the sum of _____¹³ for which payment well and truly to be made to the said Employer the Bank binds itself, his successors and assigns by these presents.

SEALED with the Common Seal of the said Bank this _____ day of _____ 20____.

THE CONDITIONS of this obligation are:

- (1) If after Bid opening the Bidder (a) withdraws his bid during the period of Bid validity specified in the Letter of Bid; or (b) does not accept the correction of the Bid Price pursuant to ITB 36;

or

- (2) If the Bidder having been notified of the acceptance of his bid by the Employer during the period of Bid validity:
 - (a) fails or refuses to execute the Contract Agreement in accordance with the Instructions to Bidders, if required; or
 - (b) fails or refuses to furnish the Performance Security, in accordance with the Instruction to Bidders.

we undertake to pay to the Employer up to the above amount upon receipt of his first written demand, without the Employer having to substantiate his demand, provided that in his demand the Employer will note that the amount claimed by him is due to him owing to

¹²In the case of a JV, the bidder should be stated as "a Joint Venture consisting of and".

¹³The Bidder should insert the amount of the guarantee in words and figures denominated in Indian Rupees. This figure should be the same as shown in Clause 19.1 of the Instructions to Bidders.

the occurrence of one or any of the four conditions, specifying the occurred condition or conditions.

This Guarantee will remain in force up to and including the date _____¹⁴ days after the deadline for submission of Bids as such deadline is stated in the Instructions to Bidders or as it may be extended by the Employer, notice of which extension(s) to the Bank is hereby waived. Any demand in respect of this guarantee should reach the Bank not later than the above date.

DATE _____ SIGNATURE OF THE BANK

WITNESS _____ SEAL _____

[signature, name, and address]

Note: All italicized text (including footnotes) is for use in preparing this form and shall be deleted from the final product.

¹⁴45 days after the end of the validity period of the Bid.

Letter of Bid – Financial Part

The Bidder must prepare the Letter of Bid on stationery with its letterhead clearly showing the Bidder's complete name and address.

Note: All italicized text is for use in preparing these forms and shall be deleted from the final products.

Date: _____

Invitation for Bid No.: _____

To:

*The Superintending Engineer,
Research Circle,
Irrigation Research Institute, Roorkee- 247667*

We, the undersigned, hereby submit the second part of our Bid, the Bid Price and Bill of Quantities. This accompanies the Letter of Technical Part:

In submitting our Bid, we make the following declarations:

- (a) Our bid shall be valid for a period of _____ *[insert validity period as specified in ITB 18.1.]* days from the date fixed for the bid submission deadline in accordance with the Bidding Documents, and it shall remain binding upon us and may be accepted at any time before the expiration of that period;
- (b) The total price of our Bid, excluding any discounts offered in item (c) below is:
 - In case of only one lot, total price of the Bid *[insert the total price of the bid in words and figures];*
 - In case of multiple lots, total price of each lot *[insert the total price of each lot in words and figures];*
 - In case of multiple lots, total price of all lots (sum of all lots) *[insert the total price of all lots in words and figures];*
- (c) The discounts offered and the methodology for their application are:
 - (i) The discounts offered are: *[Specify in detail each discount offered.]*
 - (ii) The exact method of calculations to determine the net price after application of discounts is shown below: *[Specify in detail the method that shall be used to apply the discounts];*

(d) We have paid, or will pay the following commissions, gratuities, or fees with respect to the bidding process or execution of the Contract:¹⁵

Name of Recipient	Address	Reason	Amount
.....
.....

Name of the Bidder* *[insert complete name of person signing the Bid]*

Name of the person duly authorized to sign the Bid on behalf of the Bidder** *[insert complete name of person duly authorized to sign the Bid]*

Title of the person signing the Bid *[insert complete title of the person signing the Bid]*

Signature of the person named above *[insert signature of person whose name and capacity are shown above]*

Date signed *[insert date of signing]* day of *[insert month]*, *[insert year]*

*: In the case of the Bid submitted by joint venture specify the name of the Joint Venture as Bidder

** : Person signing the Bid shall have the power of attorney given by the Bidder to be attached with the Bid Schedules.

.....
.....

¹⁵ *If none has been paid or is to be paid, indicate "none".*

Appendix to Financial Part

Bill of Quantities

Appendix to Financial Part

Bill of Quantities

S. No.	Item of Work	Qty.	Unit	BASIC RATE In Figures To be entered by the Bidder in INR	GST Amount in INR	TOTAL AMOUNT Without Taxes. In INR	TOTAL AMOUNT With Taxes. In INR	TOTAL AMOUNT In Words
1	Drilling and installation of 66 nos. groundwater monitoring wells							
1.01	Site clearance at the beginning of drilling works and site finishing after completion of all works.	66.00	Job					
1.02	Drilling of borehole required as per site minimum bore size 300 mm after reaming including water arrangement for drilling, back ashing, collecting of samples from different strata, preparing and submitting strata chart etc. In soil Complete	800.00	Mtr					
1.03	Drilling of borehole required as per site minimum bore size 250 mm after reaming including water arrangement for drilling, back ashing, collecting of samples from different strata, preparing and submitting strata chart etc. In Boulder and Rock Complete	2178.00	Mtr					
1.04	Supply of 110mm dia UPVC Plain pipe	251.00	Mtr					
1.05	Supply of 110mm dia UPVC Filter pipe with cap and mesh cloth M.L. T&P etc. all complete.	73.00	Mtr					
1.06	Supply of 100mm dia MS ERW fincut 5.40 mm thick Plain pipe with socket	1562.00	Mtr					
1.07	Supply of 100 mm dia MS ERW fincut 5.40 mm thick slotted pipe with socket	1102.00	Mtr					
1.08	Supply of 100 mm dia, 5.40 mm thick tubewell cap.	60.00	No					
1.09	Supply of 100 mm dia M.S.D.I housing clamp	66.00	No					

	complete.							
1.10	Supply and fixing of 100 mm dia Bail plug with nut & U- bolt as required.	60.00	No					
1.11	Supply of Pea gravel	251.00	Cum					
1.12	Lowering of 110 mm dia Upvc pipe and 100 mm MSERW housing pipe (Plain & Slotted pipe) as required.	3000.00	Mtr.					
1.13	Fixing of 100 mm dia, 5.40 mm thick tubewell cap.	60.00	Job					
1.14	Development of tubewell by 250 PSI Air compressor unit to the satisfaction of Engineer in charge to give a sand free discharge & Proper packing of pea gravel.	2508.00	Hrs					
2	Supply, Fixing, Installation, Fabrication & Painting of protection box and Sign Board							
2.01	Construction of Protection box of size 65 cm x 65 cm x 45 cm with 3.15 mm thick Galvanized steel sheet including Fabrication, painting with two more layers of Primer and non-corrosive all weather branded paint including locking system, 7 lever brass lock with three keys, including costs of all materials labour, wastage & additional steel, T&P etc. complete	66.00	Nos.					
2.02	Construction of 66 nos. of Sign Board of size 100 cm x 100 cm with 3.15 mm thick Galvanized steel sheet including Fabrication, painting with two more layers of Primer and non-corrosive all weather branded paint, of display board including costs of all materials labour, wastage & additional steel, T&P etc. complete	66.00	Nos.					
2.03	Writing of matter on display board with dark brightening all weather paint as per direction of EIC including costs of all materials, labour, T&P	66.00	Nos.					

	etc. complete							
2.04	Dowel tubes (Corrugated GI pipes 50 mm dia) for sign board including Fabrication, painting with two more layers of Primer and non-corrosive all weather branded paint of GI pipes, fixing with display board & foundation including costs of all materials labour, wastage & additional steel, T&P etc. complete @50% of cost of GI Pipes	66.00	Nos.					
3	Civil Work for Protection Block & Sign Board							
3.01	Providing and laying in position cement concrete of specified grade excluding the cost of centering and shuttering - All work up to plinth level 1:2:4 (1 cement : 2 coarse sand (zone-III) : 4 graded stone aggregate 20 mm nominal size)	43.27	Cum					
3.02	Centering and shuttering including strutting, propping etc. and removal of form for all heights :Foundations, footings, bases of columns, etc. for mass concrete	308.25	Sqm					
3.03	Providing and laying in position cement concrete of specified grade excluding the cost of centering and shuttering - All work up to plinth level. 1:4:8 (1 Cement : 4 coarse sand (zone-III) : 8 graded stone aggregate 40 mm nominal size).	7.53	Cum					
3.04	Earth work in excavation by mechanical means (Hydraulic excavator) / manual means in foundation trenches or drains (not exceeding 1.5 m in width or 10 sqm on plan), including dressing of sides and ramming of bottoms, lift upto 1.5 m, including getting out the excavated soil and disposal of surplus excavated soil as directed, within a lead of 50 m. For all kind of soils.	16.00	Cum					
3.05	Excavation work by mechanical means (Hydraulic excavator)/ manual means in	15.51	Cum					

	foundation trenches or drains (not exceeding 1.5m in width or 10 sqm on plan), including dressing of sides and ramming of bottoms, lift upto 1.5 m, including getting out the excavated soil and disposal of surplus excavated soils as directed, within a lead of 50 m in ordinary rock							
3.06	Providing and laying in position cement concrete of specified grade excluding the cost of centering and shuttering- all work upto plinth level 1:1.5:3 (1 cement : 1.5 coarse sand (zone-III): 3 graded stone aggregates 20 mm nominal size)	3.56	Cum					
3.07	Steel reinforcement for R.C.C. work including straightening, cutting, bending, placing in position and binding all complete upto plinth level. Thermo-Mechanically Treated bars of grade Fe-500D or more.	4890.00	Kg					
	Total Bid Price (in figures)							
	Total Bid Price (in figures)							

Note:

1. *Item for which no rate or price has been entered in will not be paid for by the Employer when executed and shall be deemed covered by the other rates and prices in the Bill of Quantities (refer: ITB Clause 14.2 and GCC Clause 41.3)*
2. *Unit rates and prices shall be quoted by the bidder in Indian Rupees [ITB Clause 14.1 and ITB Clause 15.1]*
3. *Where there is a discrepancy between the unit rate and the line-item total resulting from multiplying the unit rate by quantity, the unit rate quoted shall govern as explained in ITB Clause 36. [Note: delete this point if the e-procurement system automatically calculates the total from the unit rate and quantity]*
4. *Where there is a discrepancy between the rate in figures and words, the rates in words will govern as explained in ITB Clause 36. [Note: delete this point if the e-procurement system automatically populates the amount in words from the amount in figures]*

**FORM OF AFFIDAVIT FOR CORRECTNESS OF INFORMATION AND DOCUMENTS
SUBMITTED WITH BID**

[Reference ITB 20.2]

*[This affidavit should be on a non-judicial stamp paper of Rs.100/- and shall be attested
by Magistrate/ Sub-Judge/ Notary Public]*

I, (*name of the authorised representative
of the Bidder*) solemnly affirm and state as under:

1. I hereby certify that all the information and documents furnished with the Bid submitted online in response to IFB number date issued by (*authority inviting bids*) for (*name and identification of Goods & Related Services*) are true and correct.
2. *I hereby certify that I have been authorised by (*the Bidder*) to sign on their behalf, the Bid mentioned in paragraph 1 above.

Deponent

Place:

Date:

** This sub-paragraph is not applicable if the Bidder is an individual and is signing the Bid on his own behalf.*

Section V - Eligible Countries

Eligibility for the Provision of Goods, Works and Services in Bank-Financed Procurement

1. In reference to ITB 4.7, and 5.1, for the information of the Bidders, at the present time firms, goods and services from the following countries are excluded from this bidding process:

Under ITB 4.7 (a) and 5.1 : *None*

Under ITB 4.7 (b) and 5.1 : *None*

Section VI. Bank Policy - Corrupt and Fraudulent Practices

(Section VI shall not be modified)

Guidelines for Procurement of Goods, Works, and Non-Consulting Services under IBRD Loans and IDA Credits & Grants by World Bank Borrowers, dated January 2011:

“Fraud and Corruption:

1.16 It is the Bank’s policy to require that Borrowers (including beneficiaries of Bank loans), bidders, suppliers, contractors and their agents (whether declared or not), sub-contractors, sub-consultants, service providers or suppliers, and any personnel thereof, observe the highest standard of ethics during the procurement and execution of Bank-financed contracts.¹⁶ In pursuance of this policy, the Bank:

- (a) defines, for the purposes of this provision, the terms set forth below as follows:
 - (i) “corrupt practice” is the offering, giving, receiving, or soliciting, directly or indirectly, of anything of value to influence improperly the actions of another party;¹⁷;
 - (ii) “fraudulent practice” is any act or omission, including a misrepresentation, that knowingly or recklessly misleads, or attempts to mislead, a party to obtain a financial or other benefit or to avoid an obligation;¹⁸
 - (iii) “collusive practice” is an arrangement between two or more parties designed to achieve an improper purpose, including to influence improperly the actions of another party;¹⁹
 - (iv) “coercive practice” is impairing or harming, or threatening to impair or harm, directly or indirectly, any party or the property of the party to influence improperly the actions of a party;²⁰
 - (v) “obstructive practice” is
 - (aa) deliberately destroying, falsifying, altering, or concealing of evidence material to the investigation or making false statements to investigators in order to materially impede a Bank investigation into allegations of a corrupt, fraudulent, coercive or collusive practice; and/or threatening, harassing or intimidating any party to

¹⁶In this context, any action to influence the procurement process or contract execution for undue advantage is improper.

¹⁷ For the purpose of this sub-paragraph, “*another party*” refers to a public official acting in relation to the procurement process or contract execution. In this context, “*public official*” includes World Bank staff and employees of other organizations taking or reviewing procurement decisions.

¹⁸ For the purpose of this sub-paragraph, “*party*” refers to a public official; the terms “*benefit*” and “*obligation*” relate to the procurement process or contract execution; and the “*act or omission*” is intended to influence the procurement process or contract execution.

¹⁹ For the purpose of this sub-paragraph, “*parties*” refers to participants in the procurement process (including public officials) attempting either themselves, or through another person or entity not participating in the procurement or selection process, to simulate competition or to establish bid prices at artificial, non-competitive levels, or are privy to each other’s bid prices or other conditions.

²⁰ For the purpose of this sub-paragraph, “*party*” refers to a participant in the procurement process or contract execution.

prevent it from disclosing its knowledge of matters relevant to the investigation or from pursuing the investigation, or

- (bb) acts intended to materially impede the exercise of the Bank's inspection and audit rights provided for under paragraph 1.16(e) below.
- (b) will reject a proposal for award if it determines that the bidder recommended for award, or any of its personnel, or its agents, or its sub-consultants, sub-contractors, service providers, suppliers and/or their employees, has, directly or indirectly, engaged in corrupt, fraudulent, collusive, coercive, or obstructive practices in competing for the contract in question;
- (c) will declare misprocurement and cancel the portion of the loan allocated to a contract if it determines at any time that representatives of the Borrower or of a recipient of any part of the proceeds of the loan engaged in corrupt, fraudulent, collusive, coercive, or obstructive practices during the procurement or the implementation of the contract in question, without the Borrower having taken timely and appropriate action satisfactory to the Bank to address such practices when they occur, including by failing to inform the Bank in a timely manner at the time they knew of the practices;
- (d) will sanction a firm or individual, at any time, in accordance with the prevailing Bank's sanctions procedures,²¹ including by publicly declaring such firm or individual ineligible, either indefinitely or for a stated period of time: (i) to be awarded a Bank-financed contract; and (ii) to be a nominated²²;
- (e) will require that a clause be included in bidding documents and in contracts financed by a Bank loan, requiring bidders, suppliers and contractors, and their sub-contractors, agents, personnel, consultants, service providers, or suppliers, to permit the Bank to inspect all accounts, records, and other documents relating to the submission of bids and contract performance, and to have them audited by auditors appointed by the Bank."

²¹ A firm or individual may be declared ineligible to be awarded a Bank financed contract upon: (i) completion of the Bank's sanctions proceedings as per its sanctions procedures, including, inter alia, cross-debarment as agreed with other International Financial Institutions, including Multilateral Development Banks, and through the application the World Bank Group corporate administrative procurement sanctions procedures for fraud and corruption; and (ii) as a result of temporary suspension or early temporary suspension in connection with an ongoing sanctions proceeding. See footnote 14 and paragraph 8 of Appendix 1 of these Guidelines.

²² A nominated sub-contractor, consultant, manufacturer or supplier, or service provider (different names are used depending on the particular bidding document) is one which has either been: (i) included by the bidder in its pre-qualification application or bid because it brings specific and critical experience and know-how that allow the bidder to meet the qualification requirements for the particular bid; or (ii) appointed by the Borrower.

PART 2 – Works Requirements

Section VII - Works Requirements

Specifications

Specifications

1.0 General specifications;

The work will be construction of 66 (sixty) numbers of piezometers (tubewells) in 5 districts of Uttarakhand to monitor groundwater level and quality. All the piezometers constructed, will be provided with strong protective cover for protection of piezometers. The designs of typical piezometers in all type of soil are shown in drawings attached.

1.1 A piezometer is a tube well in areas of rocks in all types and hardness & alluvium, constructed to measure and monitor the ground water level and ground water quality of the area. Monitoring of ground water regime by measurement of ground water levels and analyzing the ground water quality is the prime objective of National Hydrology Project. The rocky areas are made up of rocks below a few meters of overburden below ground level. Thus construction of piezometers will involve all the process which are involved in the construction of a bore hole in all types of soil. Construction of Strong Protection Cover will involve all the process involved in Protection Device.

1.2 The tentative sites for constructions of piezometers have been fixed and the locations of the piezometer are stated in tables appended and the locations are shown on annexures appended. As indicated in the statement the names of villages where the piezometers are to be drilled are shown along with the tentative depth of piezometers.

1.3 Piezometers (Borehole) in All Types of Soil

The list of bore holes sites, with tentative depth are listed in the statement appended with locations. The drawing of a piezometer bore hole is shown as in Drawing No 1 .The process of construction of piezometer (borehole) involve drilling of pilot hole up to the depth decided by site incharge/ EIC, lowering and fixing of a casing pipe and then drilling a naked bore hole up to the specified depth. The casing pipe used for over burden will be as per the specifications given.

1.3.1 The estimated number of piezometers in as stated in the name of work. The estimated depth of these piezometers, have been fixed depending on the existing water level behavior of the area and the list of piezometers in different areas of Uttarakhand has been clearly stated in statements appended. Construction of one piezometers will involve construction one tube well involving all the process as stated in 1.3.0 in one continuous stretch beginning from drilling to fixing of a well cap. Therefore, once the contractor brings the drilling rig of the tube well, he will complete the construction of piezometer in one continuous process of drilling, pipe lowering, gravel packing etc. up to the fixing of the well cap. The contractor will immediately make arrangement for compressor and start developing the tube well till the sand free water discharge is ascertained by the Site Incharge/EIC. Part work of the construction of piezometers is not allowed.

1.3.3 The contractor will deploy trained and experienced drilled for drilling of tube well so that the works do not hamper. The contractor will deploy trained, skilled, strong and experienced labours that have been associated with this type of work. The contractor will deploy trained rig driver who can drive the rig clearly and safely and make it reach to the spot where the tube well has to be drilled. The contractor will insure all the labours, drillers, drivers etc. for life as well for minor/major accidents and also for any disability

caused due to minor/major accident. The contractor produces the necessary papers of insurance before actual work is commenced. Starting work will not be allowed till necessary verification of insurance has been done for labours (men/women or labour of any other form). The EIC will check and certify the authenticity and validity of insurance papers. If any wrong information is stated or used in case of insurance the whole responsibility will be on the contractor. The contractor will read the clause on insurance on page No.124 GCC Clause No.13 and seek clarification if need be.

1.3.4 The contractor will collect location of the piezometer to be drilled from the site incharge/EIC. The representative of the EIC will show the spot of drilling of tube well to the contractor.

1.3.5 The EIC will give the depth of the tube well to the contractor in writing and the contractor will not drill more than the depth received from the EIC. The contractor will verify the exact location of the site and then deploy his rig. The contractor will clarify all doubts regarding the site location and depth and then deploy the rig for increasing or decreasing the depth of the tube well with the site incharge. Hydrologist will seek timely permission of the EIC and convey the decision to the driller, contractor or his representative.

1.3.6 The contractor and his drilling team will work in experienced, matured, workman like fashion and whole process of construction piezometers will be done with perfect peace. The contractor and his team must behave and work in discipline and peacefully. Consumption of liquors, drug or other intoxicating material which may hamper the proper peace and harmony of the work is prohibited in working area. If any person of the team of the contractor of his accomplice of any kind is found drunk, intoxicated or unfared the Site incharge/ EIC will instruct to remove such person from his site. The contractor will make arrangement for immediate replacement of the person.

1.3.7 The contractor will procure and stack material as per specification indicated. The contractor will clean the site plan at the stacking of material on site and then deploy the rig. The work will be carried out as per the specifications laid out in next section on item wise specifications. The contractor will keep working field book, rig log book, drilling log book, marked, core/strata box, clear drinking water facility, first aid box, leak proof water tanker for drilling work and all necessary arrangements for smooth and healthy atmosphere at site. The contractor will keep perfect communication with site incharge/EIC. The decision of the EIC will be final in all the above matters.

1.4 The contractor will deploy a suitable D.T.H. percussion Type of rig for drilling in rocky terrain and reverse rotary in alluvium. The use of suitable compressor for the dia. & depth of casing pipe as specified and complete the piezometer (borehole). A normal drilling in hard rock area and construction of a bore hole to the specified depth should not take more than 3 days. The contractor will make arrangement of sufficient drilling rods, drilling bits for rocky terrain, compressor of specified capacity and complete the work in perfect workman like fashion.

1.5 Technical Specifications of Materials

Any rejected materials should be replaced by the contractor at his cost. Contractor will see the drawings for construction.

In this work following quality of materials are required to be used, which should be brought by the contractor at his cost and no any extra payment will be given for carting,

loading, unloading, stacking etc. for the materials to be used in the construction of piezometers at various locations.

S. N.	MATERIAL	Quantity
1	100 mm dia. ERW Pipe	as per recommendation of the Senior Geohydrologist /EIC looking to the design & depth of the piezometer
2	Well Cap, with locking arrangement as per drawing	One for one for each piezometer
3	Well Plug/ Bottom Plug of required dia. to the bottom of pipe assembly of borewell as per IS 2800 (Part 1), 100 mm	Only for boreholes in alluvium
4	(a) Cement, (b) Sand, (FM-2.5-3.0) (c) Aggregate (10-40 mm) (e) 3.15 mm thick GI sheet for protection box and fencing.	As may require and as per Specifications as laid down relevant BIS codes.

1.6 All materials required in these works shall be inspected by EIC or his representative before the usage. Necessary testing certificates from testing laboratories certified by Government of Uttarakhand/ Government of India as per IS norms should be provided by the contractor at his own cost in case of pipe to be lowered in concerned pipe assembly. If no such testing certificate is produced by the contractor, The EIC will get testing done at the expense of contractor, if need be, and as a result any delay in the work takes place, the employer will not be responsible for the same.

2 Detailed Technical Specifications of Materials:

2.1 Pipes:

A) The Electric Resistance Welded (ERW) Mild Steel plain ended blank pipes and slotted pipes will be connected to each other by welding with the help of Stiffeners in piezometer.

(B) The upper most end of pipe assembly and casing pipe above ground level of each piezometer should be threaded at one end in which the well cap should fit in.

2.1.1 100 mm Dia. Pipes:

Heavy duty 'C' class mild steel (M.S.) ERW/HFIW plain ended pipes both the ends bevel faced. General specifications and all test of pipes should be confirming to IS: 8110 except changes specified as below:

Wall thickness	The wall thickness of pipe should be 5.40 mm. The thickness tolerance shall be as per of IS 8110 or any amendment thereof.
Length of Pipe	The length of 6 meters of each pipe, (\pm) 0.25-meter tolerance will be allowed. However, total length should not be less than recommended by the EIC, looking to the hydrogeological condition of the area. 1.00 mt. Extra length of pipes is to be provided above ground level in each piezometer.
Diameter	Outer Max. 116.5 mm & Minimum 113.9 mm
Hydraulic pressure	50 kg/cm ² (Minimum)

Weight of pipe	19.5 kg/mt. (Minimum) Screwed & Socketed Tolerance in weight shall be permitted as per of IS 1239 (Part I-)
Tensile strength of pipe	At least 320 N/ mm ² (Minimum)
Beveling of Ends	Both ends should be smooth and bevel faced with chamfer of 30° ± 50° to the perpendicular to axis of the pipes.

Pipes should be coated with black bituminous paint on the outside surface only as mentioned in IS: 4270 (latest). The test certificate from government approved laboratory and the same will have to be produced by the contractor before utilizing the pipes in the piezometer. The testing should be done by the contractor at his cost.

2.1.2 Well Cap For 100 mm Pipes:

It should be made from a mild steel 6 mm thick & 150 mm length of each coupling which should be suitable for 100 mm (N.B.) pipes with threading. The top of the coupling should be covered by welding a mild steel plate of 7 mm thickness. The L and key arrangement should be done to open the well cap.

3. ITEMWISE SPECIFICATION

3.0 Construction of Piezometer:

3.1 Definition:

In this contract a piezometer will mean a tube well or bore hole in area of all type of soil and hardness drilled to a specified depth followed by all procedures for completion of a tube well and bore hole. The EIC will declare the tube well and bore hole as a piezometer as per his satisfaction. EIC will declare the tube well and bore hole as a piezometer, increase the depth of piezometer as per his discretion. In case of dispute about the type of strata that encounter during drilling the decision of the Nodal Officer, National Hydrology Project, Uttarakhand will be final and binding to the contractor for payments of the work. After receiving the completion certificate from the EIC, the contractor will shift the rig, clear and clean the site and immediately will take up the work of Platform & Protective Cover.

3.2 Construction of Piezometer in all type of soil:

3.2.1 The contractor shall deploy suitable D.T.H. (Down the hole) drilling rig with percussion movements and fitted with air compressor with capacity of 1400/1500 CFM with 350/450 P.S.I. (per square inch). Contractor shall have to drill the pilot borehole of 350 mm dia. in over burden formation till hard rock is encountered. The depth of overburden will be decided by the Site incharge/ EIC.

The Site Incharge/ EIC will recommend casing pipe of 350 mm dia as per the over burden thickness with inverted reducer (300 mm to 325 mm) at bottom to be used for the piezometer to protect filling of loose weathered materials one meter of this casing pipes is to be kept above ground level. The top end of this pipe will be threaded on which well cap can be fixed. The Site Incharge EIC will inspect the casing pipes before lowering.

After lowering of casing pipes, the cement grouting should be provided around the pipes up to depth of about 1.0 mt. By pouring cement slurry around pipes. The bore should be kept idle from 3 to 4 hours to settle the cements slurry. After settlement of cement grouting the annular space around pipes should be filled up by sticky clay, upto ground level.

3.2.2 Then drilling of 350 mm dia. by hammer bit should be started in the casing pipe upto the depth as given or directed by Site Incharge/EIC. No drilling beyond the depth mentioned in the tended below ground level shall be done without prior instructions of EIC or Site Incharge/ or his representative. The EIC shall have the power to reduce or increase the depth as per hydrogeological conditions. Payment of excess or any item of work & materials shall be regulated as per approved prevailing scheduled rates of Govt. of Uttarakhand/DSR (when scheduled rates of Govt. of Uttarakhand are not available).

Samples of drill cuttings taken at every 3 mts. depth or shorter interval as per Site Incharge/EIC instruction if strata changes, shall be carefully preserved at site in strata box so that any dispute regarding strata for payments.

3.2.3 After completion of drilling the piezometer shall be cleaned and developed by the air compressor till sand/rock cutting free discharge is obtained, to the satisfaction of the Site Incharge/EIC. The contractor should give perfect sounding of drilling depth before shifting of rig to in presence of EIC/representative of EIC.

3.2.4 After completion of the above works the contractor shall arrange for clearing and cleaning the surrounding area of the tube well. The contractor should level, clear, pickup his tools, fill-up the mud pit, level it and clear the area as it was earlier.

Once the tube well is completed and the completion certificate is obtained by the contractor from the EIC, the constructions work Plate form & Protection Cover as per given drawing immediately taken up by the contractor.

3.2.5 The measurement for the depth of the piezometer will be done by the Site Incharge/ EIC and the contractor will be paid accordingly. If the depth of bore hole exceeds the specified depth the contractor will not be paid for the extra depth.

3.3. Protection Box, Fencing and Sign Board

3.3.1 Protection Cover of 66 Nos. Piezometer in all 5 Districts: -

Excavation: Excavation of foundation trench for outer wall for rectangular cement concrete platform of size 100 cm x 100 cm x 40 cm depth as shown in drawing.

Foundation: P.C.C. 1:2:4 with 20mm-4.75 mm graded aggregate will laid in trench up to 30 cm in thickness over P.C.C. 1:4:8 with 40mm-4.75 mm graded aggregate will laid in trench up to 10 cm in thickness.

Filling in plinth: 1:2:4 P.C.C shall laid in plinth as filling material on ground level of 30 cm thick to make the base for platform on which protection box will be placed.

Painting: One coat of painting with epoxy paint of approved shade and make over steel surface including cleaning the surface.

Signboard: Signboard of size 100 cm x 100 cm to be fixed on the place specified as per drawing.

3.4 Acceptance of the Piezometers

3.4.1 Construction of piezometer to the specified depth include drilling, pipe lowering, and development by air compressor as specified.

3.4.2 Discharge should be sand free and sand contents are not more than 10 parts per million.

3.4.3 Clear sounding of the piezometer.

-
- 3.4.4 The piezometer should not be eccentric beyond specified limit as per IS: 2800. Deviation should not be more than 100 mm at 30 mt depth. If the deviation is more than 100 mm at 30 mts depth 5% reduced payment will be made if the bore, is otherwise, acceptable.
- 3.4.5 The Plat form & Protection Cover will make up for piezometer in district wise as shown in drawing.

3.5 Records:

A strata chart in the standard form approved by the Site Incharge/EIC shall be maintained at the site and shall contain the following information.

- a. Description and depth of various strata encountered.
- b. Strata level below ground level.
- c. Diagram showing exact location of filters, blank pipes for each bore.
- d. Position of joints between slotted and blank pipes.
- e. Rate of progress of drilling on time log basis.
- f. 5 copies of strata chart will be forwarded to EIC/ Site Incharge at the time of handing over of the piezometer.

3.6 Drilling beyond Specified Depth and Abandoning Drilling work:

No drilling beyond the depth mentioned in the tender shall be done without prior written instructions of EIC or Site Incharge. The EIC shall have the power to reduce or increase the depth of the piezometers by 10% of the piezometer. Payment of excess work shall be regulated as per tendered rate for the estimated depth.

If the depth of the piezometer is increased as per the discretion of the EIC the contractor will be paid proportionately as per the rate of next slab of piezometer approved in the tendered cost.

If the work of piezometers cannot be completed because of any fault on the part of the contractor and work has to be abandoned at that stage, because of faulty workmanship or negligence of the agency, no payment shall be made.

However, if the failure of the piezometer is due to local hydrogeological conditions and after lowering of pipes the EIC may declare the piezometer as failure and the contractor is not responsible, in that event full payment will be made as per tendered rates.

If the failure of the piezometer is due to local hydrogeological conditions and pipes are not to be lowered, the agency would be paid for the work done by them as per tendered rates.

Drawings

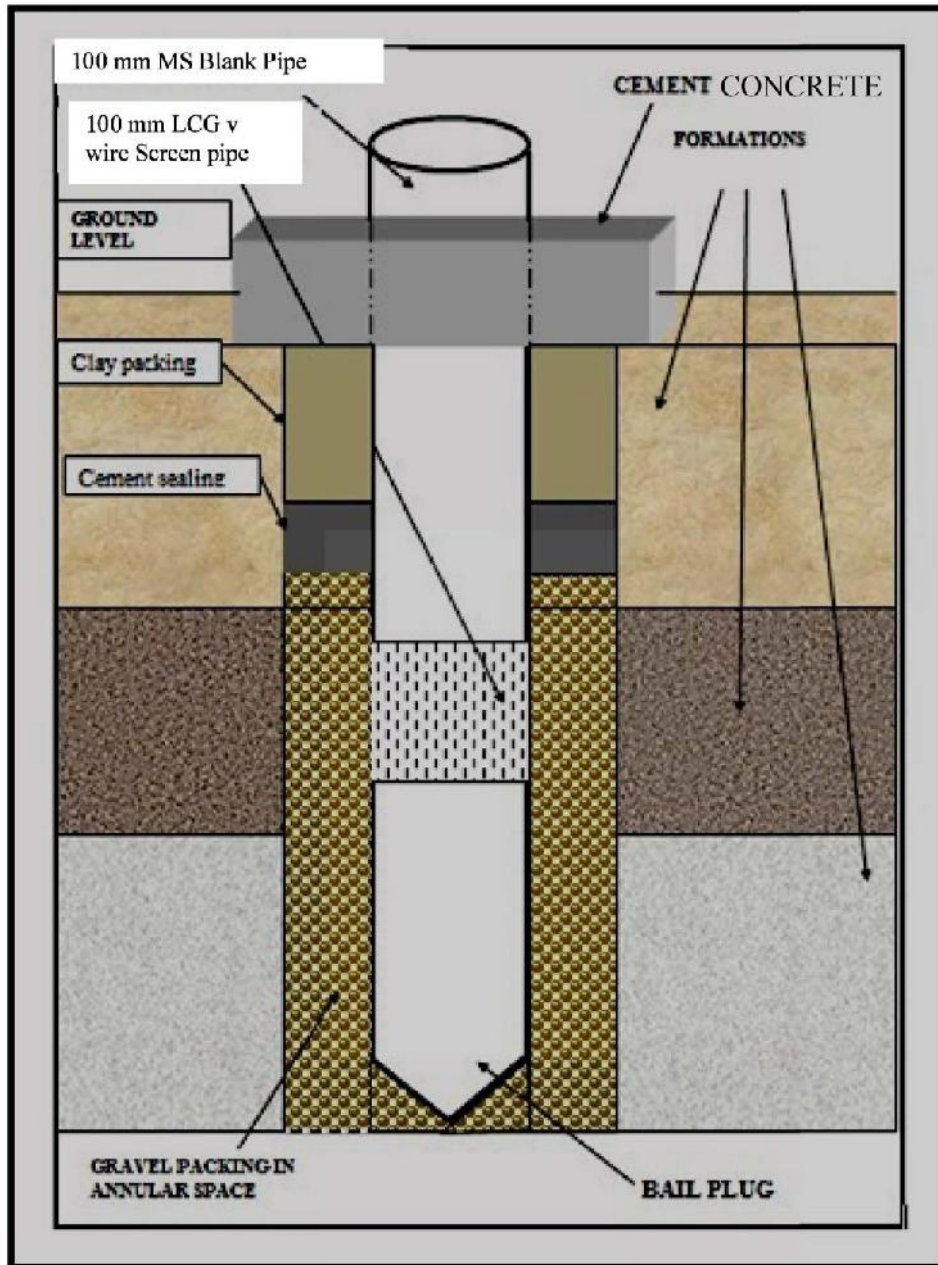

Drawing 1: A Schematic Diagram of Piezometer

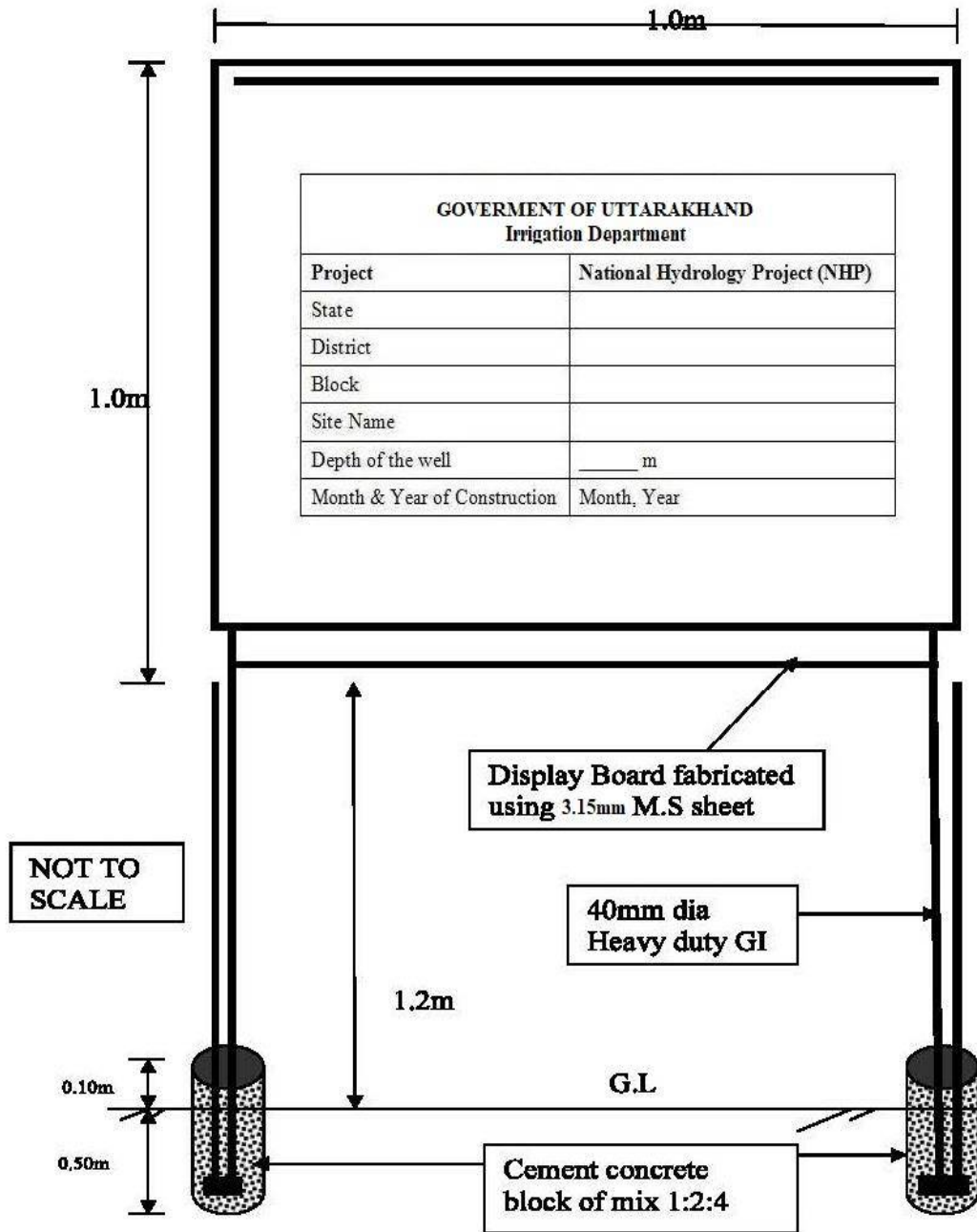

Drawing 2: A Schematic Diagram of Display Board

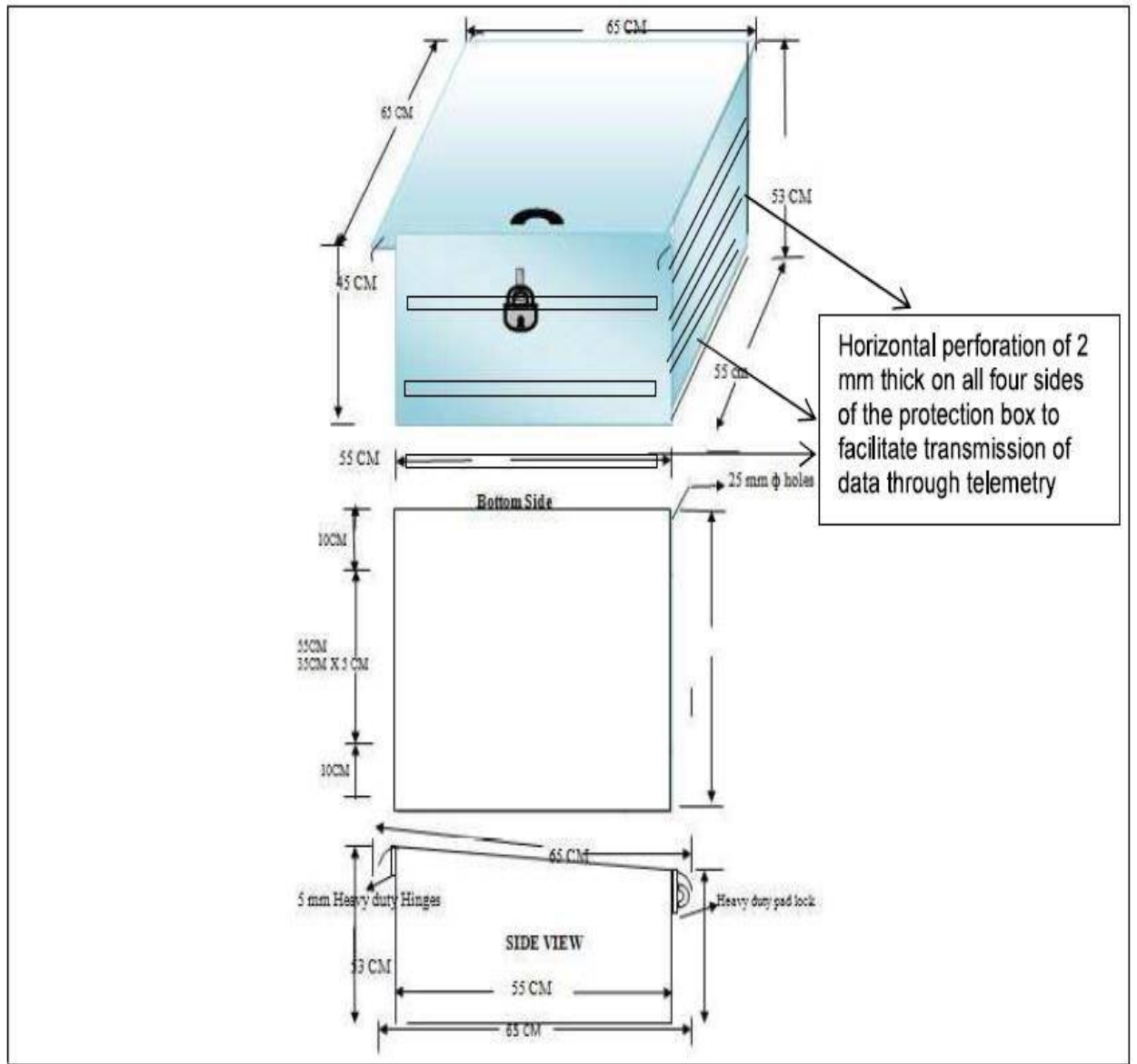

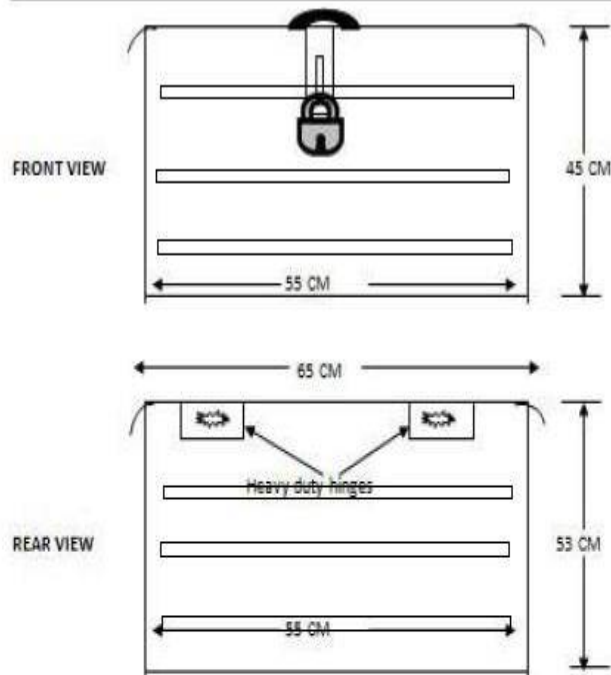

Cover Plate Size:

- 65cm X 65cm (with Handle & Lock)
- The cover plate should have minimum 5mm extra projections on all sides of the box to safe guard the box and the lock against rain
- The edges of the sheet should not be sharp but should be rounded off
- The plate should be made of GI sheet with a minimum thickness of 3.15mm.

Drawing 3: A Schematic Diagram of Protection Box

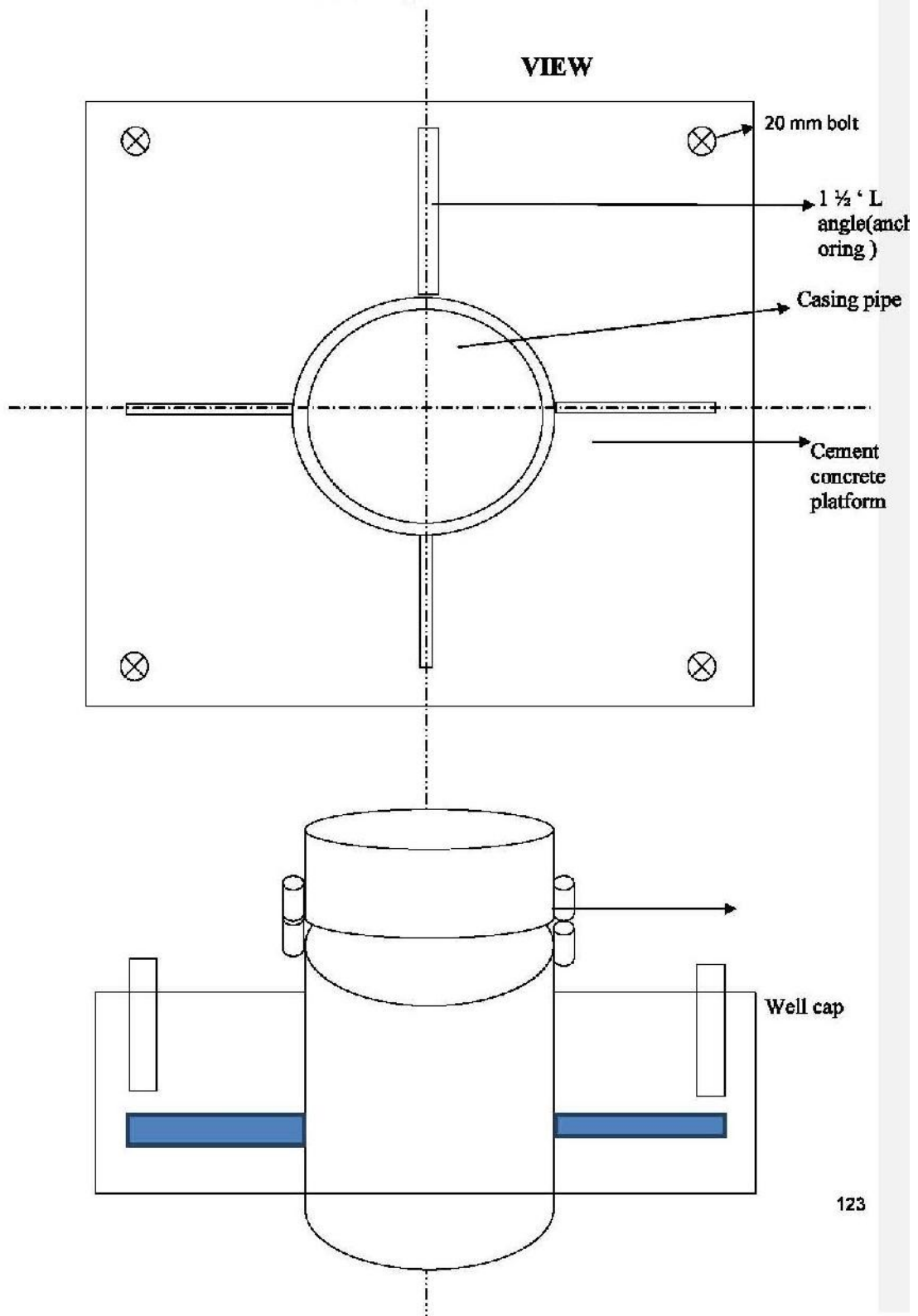

Drawing 4: A Schematic Diagram Cement/Concrete Platform & Well Cap

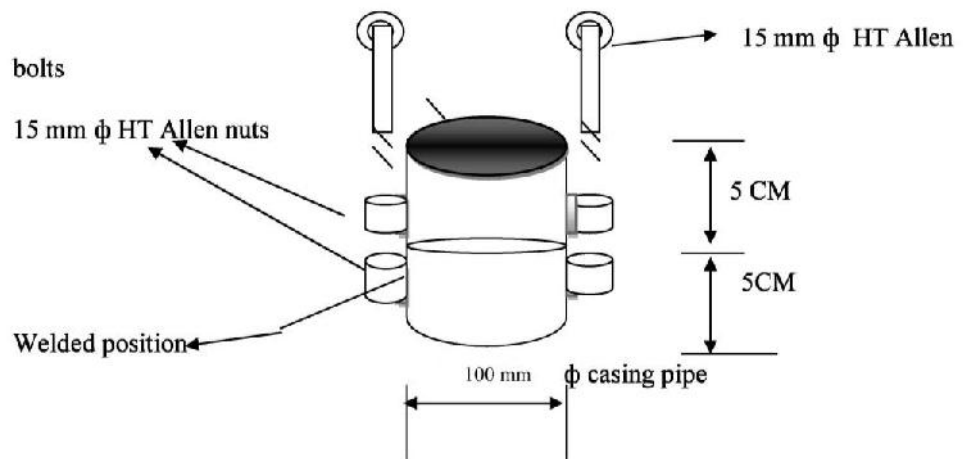

Drawing 5: A Schematic Drawing of Well cap

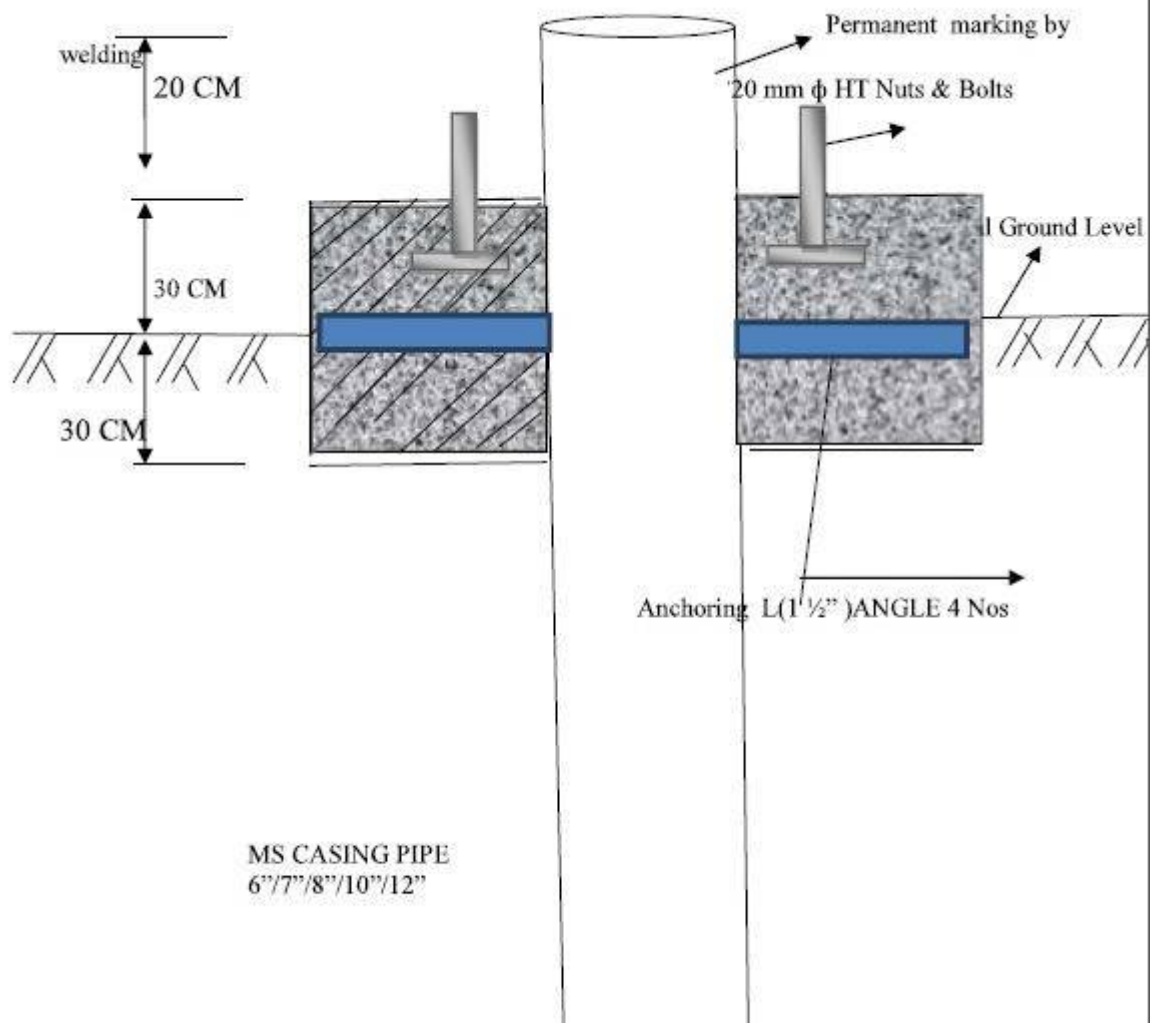

Drawing 6: A Schematic Drawing of Cement Concrete Plat Form



Platform Details: (Annexure V (b))

A cement/ concrete platform measuring 1.0 X 1.0 X 0.6 m (0.30 m above ground level and 0.30m below ground level) around the well casing is to be provided over which protection box is to be provided. The concrete mix ratio is 1:2:4

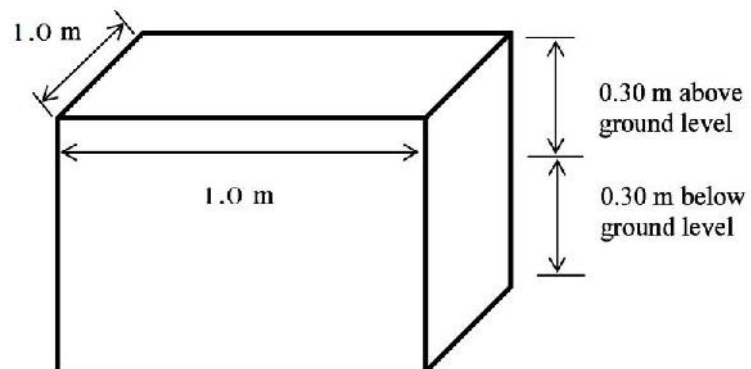

List of Piezometer Site
Tentative Location of the installation of service/instruments
Proposed Piezometer/DWLR Station under NHP, Irrigation Department
Uttarakhand

S. No.	Name of District	Name of Location	Lat. (Deg. N)	Long. (Deg. E)	Proposed Depth of Piezometer
1	Haridwar	Manglaur	29.785	77.857	90
2		Iqbalpur	29.872	77.793	90
3		Rehmatpur	29.902	77.948	90
4		Ibrahimpur Deh	29.895	77.867	90
5		Shikarpur	29.804	77.949	90
6		Kotwal	29.785	77.790	90
7		Mohitpur	29.929	77.774	100
8		Banjarewala	30.124	77.883	100
9		Fakhreda	29.894	77.735	100
10		Rasulpur	29.711	78.115	90
11		Kuankheda	29.758	77.978	90
12		Prahladpur	29.684	77.989	90
13		Roshanabad	29.971	78.073	120
14		Bhaldiyana Colony Pathari	29.795	78.077	120
15		Pathari	29.832	78.074	120
16		Jiyapota	29.878	78.128	120
17		Teliwala	29.952	77.968	120
18		Aurangabad	29.987	78.007	120
19	Nainital	Haldwani	29.216	79.527	120
20		Chorgaliya	29.105	79.694	120
21		Lamachaur	29.223	79.431	120
22		Chakluwa	29.249	79.358	120
23		Kaladhungi	29.281	79.349	100
24		Bailpadav	29.311	79.204	100
25		Chhoi	29.354	79.146	120
26		ID Ramnagar	29.395	79.132	120
27	US Nagar	Pantnagar	29.031	79.469	90
28		Rudrapur	28.994	79.402	90
29		Rameshwaram	28.947	79.462	90
30		Kichha	28.909	79.513	90
31		Sisaiya	28.878	79.676	90
32		Sitarganj	28.931	79.702	90
33		Wamanpuri	28.955	79.697	90
34		Jhankat	28.940	79.901	90
35		Khatima	28.925	79.961	90
36		Tanakpur	28.920	79.965	90
37	Chakarpur	28.957	80.006	90	

38		Dhela	29.346	79.007	90
39		ITI Kashipur	29.190	78.993	90
40		Mahuakheraganj	29.136	78.943	90
41		Jaspur	29.278	78.832	90
42		Patrampur	29.334	78.874	90
43		Dineshpur	29.045	79.319	90
44		Gadarpur	29.043	79.245	90
45		Bajpur	29.159	79.154	90
46		Bannakhera	29.246	79.169	90
47	Dehradun	Chhiderwala	30.087	78.186	120
48		Rishikesh	30.101	78.288	120
49		Satya Narayan mandir	30.048	78.215	120
50		Lacchiwala	30.210	78.133	120
51		Jhabrawala	30.142	78.097	120
52		Doiwala	30.179	78.124	120
53		Subhasnagar	30.272	77.991	120
54		Mehuwala	30.312	77.982	120
55		Ganeshpur	30.303	77.911	100
56		Selakui	30.367	77.962	100
57		Jhajhra	30.346	77.918	100
58		Jhibarhedi-2	30.297	77.936	100
59		Dhakrani	30.455	77.733	120
60		Dakpaththar	30.494	77.790	120
61		Bairagiwala	30.430	77.753	120
62		Shekhowala	30.361	77.809	120
63		Redapur	30.409	77.793	120
64		Timli	30.372	77.722	120
65		Pauri	Sigaddi	29.791	78.411
66	Kotdwar		29.742	78.519	120

Note:

- (i) The DWLRs with Telemetry system shall be supplied, installed and commissioned on the Piezometers located at different places within the 5 districts of Uttarakhand covering various river basins under the supervision of the respective Geo-hydrogeologist.

(ii) The location/numbers of DWLR, as proposed, may vary depending upon the field condition/requirement.

PART 3 – Conditions of Contract and Contract Forms

Section VIII. General Conditions of Contract

These General Conditions of Contract (GCC), read in conjunction with the Particular Conditions of Contract(PCC) and other documents listed therein, should be a complete document expressing fairly the rights and obligations of both parties.

These General Conditions of Contract have been developed on the basis of considerable international experience in the drafting and management of contracts, bearing in mind a trend in the construction industry towards simpler, more straightforward language.

General Conditions of Contract

A. General

1. Definitions

1.1 Boldface type is used to identify defined terms.

- (a) **The Accepted Contract Amount** means the amount accepted in the Letter of Acceptance for the execution and completion of the Works and the remedying of any defects.
- (b) Not used.
- (c) **The Adjudicator or Dispute Review Expert** is the person appointed jointly by the Employer and the Contractor to resolve disputes in the first instance, as provided for in GCC 23.
- (d) **Bank** means the financing institution **named in the PCC**.
- (e) **Bill of Quantities** means the priced and completed Bill of Quantities forming part of the Bid.
- (f) **Compensation Events** are those defined in GCC Clause 42 hereunder.
- (g) **The Completion Date** is the date of completion of the Works as certified by the Project Manager, in accordance with GCC Sub-Clause 53.1.
- (h) The **Contract** is the Contract between the Employer and the Contractor to execute, complete, and maintain the Works. It consists of the documents listed in GCC Sub-Clause 2.3 below.
- (i) The **Contractor** is the party whose Bid to carry out the Works has been accepted by the Employer.
- (j) The **Contractor's Bid** is the completed bidding document submitted by the Contractor to the Employer.
- (k) The **Contract Price** is the Accepted Contract Amount stated in the Letter of Acceptance and thereafter as adjusted in accordance with the Contract.
- (l) **Days** are calendar days; months are calendar months.
- (m) Not used.
- (n) A **Defect** is any part of the Works not completed in accordance with the Contract.
- (o) The **Defects Liability Certificate** is the certificate issued by Project Manager upon correction of defects by the Contractor.
- (p) The **Defects Liability Period** is the period named in the

PCC pursuant to Sub-Clause 34.3 and calculated from the Completion Date.

- (q) **Drawings** means the drawings of the Works, as included in the Contract, and any additional and modified drawings issued by (or on behalf of) the Employer in accordance with the Contract, include calculations and other information provided or approved by the Project Manager for the execution of the Contract.
- (r) The **Employer** is the party who employs the Contractor to carry out the Works, as **specified in the PCC**.
- (s) **Equipment** is the Contractor's machinery and vehicles brought temporarily to the Site to construct the Works.
- (t) **"In writing" or "written"** means hand-written, type-written, printed or electronically made, and resulting in a permanent record;
- (u) The **Initial Contract Price** is the Contract Price listed in the Employer's Letter of Acceptance.
- (v) The **Intended Completion Date** is the date on which it is intended that the Contractor shall complete the Works. The Intended Completion Date is **specified in the PCC**. The Intended Completion Date may be revised only by the Project Manager by issuing an extension of time or an acceleration order.
- (w) **Materials** are all supplies, including consumables, used by the Contractor for incorporation in the Works.
- (x) **Plant** is any integral part of the Works that shall have a mechanical, electrical, chemical, or biological function.
- (y) The **Incharge** or **Engineer-in-Charge (EIC)** is the person **named in the PCC** (or any other competent person appointed by the Employer and notified to the Contractor, to act in replacement of the Project Manager) who is responsible for supervising the execution of the Works and administering the Contract.
- (z) **PCC** means Particular Conditions of Contract
- (aa) The **Site** is the area **defined as such in the PCC**.
- (bb) **Site Investigation Reports** are those that were included in the bidding documents and are factual and interpretative reports about the surface and subsurface conditions at the Site.
- (cc) **Specification** means the Specification of the Works included in the Contract and any modification or addition made or approved by the Project Manager.
- (dd) The **Start Date** is **given in the PCC**. It is the latest date

when the Contractor shall commence execution of the Works. It does not necessarily coincide with any of the Site Possession Dates.

- (ee) A **Subcontractor** is a person or corporate body who has a Contract with the Contractor to carry out a part of the work in the Contract, which includes work on the Site.
- (ff) **Temporary Works** are works designed, constructed, installed, and removed by the Contractor that are needed for construction or installation of the Works.
- (gg) A **Variation** is an instruction given by the Project Manager which varies the Works.
- (hh) The **Works** are what the Contract requires the Contractor to construct, install, and turn over to the Employer, **as defined in the PCC**.

- 2. Interpretation**
 - 2.1 In interpreting these GCC, words indicating one gender include all genders. Words indicating the singular also include the plural and words indicating the plural also include the singular. Headings have no significance. Words have their normal meaning under the language of the Contract unless specifically defined. The Project Manager shall provide instructions clarifying queries about these GCC.
 - 2.2 If sectional completion is **specified in the PCC**, references in the GCC to the Works, the Completion Date, and the Intended Completion Date apply to any Section of the Works (other than references to the Completion Date and Intended Completion Date for the whole of the Works).
 - 2.3 The documents forming the Contract shall be interpreted in the following order of priority:
 - (a) Agreement,
 - (b) Letter of Acceptance,
 - (c) Contractor's Bid & Priced Bill of Quantities,
 - (d) Particular Conditions of Contract,
 - (e) General Conditions of Contract including Appendices,
 - (f) Specifications,
 - (g) Drawings, and
 - (h) Joint Venture Agreement [where applicable]
 - (i) any other document **listed in the PCC** as forming part of the Contract.
- 3. Language and Law**
 - 3.1 The language of the Contract and the law governing the Contract are **stated in the PCC**.
Salient features of major labour and other laws that are

applicable to construction industry in India are given as Appendix 1 to these General Conditions of Contract.

3.2 Throughout the execution of the Contract, the Contractor shall comply with the import of goods and services prohibitions in the India when

(a) as a matter of law or official regulations, India prohibits commercial relations with that country; or

(b) by an act of compliance with a decision of the United Nations Security Council taken under Chapter VII of the Charter of the United Nations, India prohibits any import of goods from that country or any payments to any country, person, or entity in that country.

4. Project Manager's Decisions

4.1 Except where otherwise specifically stated, the Project Manager shall decide contractual matters between the Employer and the Contractor in the role representing the Employer.

However, if the Project Manager is required, under the rules and regulations and orders of the Employer, to obtain approval of some other authorities for specific actions, he will so obtain the approval. Provided further that any requisite approval shall be deemed to have been given by the Employer for any such authority exercised by the Project Manager.

5. Delegation

5.1 Unless otherwise **specified in the PCC**, the Project Manager may delegate any of his duties and responsibilities to other people, except to the Adjudicator/Dispute Review Expert, after notifying the Contractor, and may revoke any delegation after notifying the Contractor.

6. Communications

6.1 Communications between parties that are referred to in the Conditions shall be effective only when in writing. A notice shall be effective only when it is delivered. All oral instructions shall be confirmed in writing in seven working days.

7. Subcontracting

7.1 The Contractor may subcontract with the approval of the Project Manager upto a ceiling **specified in PCC**, but may not assign the Contract without the approval of the Employer in writing. Subcontracting shall not alter the Contractor's obligations.

7.2 The Project Manager should satisfy himself before recommending to the Employer whether:

a) the circumstances warrant such sub-contracting; and,

b) the sub-Contractor so proposed for the Work possesses the experience, qualifications and equipment necessary for the job proposed to be entrusted to him in proportion to the quantum of Works to be sub-contracted.

7.3 If payments are proposed to be made directly to that sub-contractor, this should be subject to specific authorization by the prime contractor so that his arrangement does not alter the

contractor's liability or obligations under the contract.

7.4 The Contractor shall not be required to obtain any consent from the Employer for:

- (a) the sub-contracting of any part of the Works for which the Sub-Contractor is already named in the contract;
- (b) the provision for labour, or labour component, and,
- (c) the purchase of materials which are in accordance with the standards specified in the contract.

(Note: 1. All bidders are expected to indicate clearly in the bid, if they proposed sub-contracting elements of the works amounting to more than 10 percent of the Bid Price. For each such proposal the qualification and the experience of the identified sub-contractor in the relevant field should be furnished alongwith the bid to enable the Employer to satisfy himself about their qualifications before agreeing for such sub-contracting and include it in the contract. In view of the above, normally no additional sub-contracting should arise during execution of the contract.

2. However, [a] sub-contracting for certain specialized elements of the work is not unusual and acceptable for carrying out the works more effectively; but vertical splitting of the works for sub-contracting is not acceptable. [b] in any case, proposal for sub-contracting in addition to what was specified in bid and stated in contract agreement will not be acceptable if the value of such additional sub-contracting exceeds 25% of value of work which was to be executed by Contractor without sub-contracting.

3. Assignment of the contract may be acceptable only under exceptional circumstances such as insolvencies/liquidation or merger of companies etc.)

8. Other Contractors

8.1 The Contractor shall cooperate and share the Site with other contractors, public authorities, utilities, and the Employer between the dates given in the Schedule of Other Contractors, as **referred to in the PCC**. The Contractor shall also provide facilities and services for them as described in the Schedule. The Employer may modify the Schedule of Other Contractors, and shall notify the Contractor of any such modification.

-
- 9. Personnel and Equipment**
- 9.1 The Contractor shall employ the key personnel and use the equipment identified in its Bid and **referred to in the PCC**, to carry out the Works or other personnel and equipment approved by the Project Manager. The Project Manager shall approve any proposed replacement of key personnel and equipment only if their relevant qualifications or characteristics are substantially equal to or better than those proposed in the Bid.
- 9.2 The Project Manager may require the Contractor to remove from the Site of Works, a member of the Contractor's staff or his work force, who:
- (a) persists in any misconduct or lack of care,
 - (b) carries out duties incompetently or negligently,
 - (c) fails to conform with any provisions of the Contract, or
 - (d) persists in any conduct which is prejudicial to safety, health, or the protection of the environment.
- 9.3 If the Employer, EIC or Contractor determines, that any employee of the Contractor be determined to have engaged in corrupt, fraudulent, collusive, coercive, or obstructive practice during the execution of the Works, then that employee shall be removed in accordance with Clause 9.2 above
- 9.4 In all the above cases, the contractor shall ensure that the person leaves the site within seven days and has no further connection with the work in the contract. The Contractor shall appoint a suitable replacement within 28 days or earlier as may be agreed to between the Project manager and the Contractor.
- 9.5 The Contractor shall not employ any retired Gazetted officer who has either not completed two years after the date of retirement or has not obtained permission from the Government authorities for employment with the Contractor²³.

²³Based on Government Directives.

- 9.6 The Contractor shall, unless otherwise provided in the Contract, make his own arrangements for the engagement of all staff and labour, local or other, and for their payment, housing, feeding and transport. The Contractor shall, if required by the Project Manager, deliver to the Project Manager a return in detail, in such form and at such intervals as the Project Manager may prescribe, showing the staff and the numbers of the several classes of labour from time to time employed by the Contractor on the Site and such other information as the Project Manager may require.
- Compliance with Labour Regulations**
- 9.7 During continuance of the Contract, the Contractor and his Sub-Contractors shall abide at all times by all existing labour enactments and rules made there under, regulations, notifications and bye laws of the State or Central Government or local authority and any other labour laws (including rules), regulations, bye laws that may be passed or notification that may be issued under any labour law prevailing on the Base Date either by the State or the Central Government or the local authority. The Contractor shall keep the Employer indemnified in case any action is taken against the Employer by the competent authority on account of contraventions including amendments. If the Employer is caused to pay or reimburse, such amounts as may be necessary to cause or observe, or for non-observance of the provisions stipulated in the notifications/bye laws/Acts/Rules/regulations including amendments, if any, on the part of the Contractor, the Project Manager/ Employer shall have the right to deduct any money due to the Contractor including his amount of performance security. The Employer/ Project Manager shall also have right to recover from the Contractor any sum required or estimated to be required for making good the loss or damage suffered by the Employer.
- 9.8 The employees of the Contractor and the Sub-Contractor in no case shall be treated as the employees of the Employer at any point of time.
- 9.9 The Contractor shall duly comply with the provisions of the Apprentices Act 1961 (III of 1961) and the rules made there under, and comply, failure or neglect to shall be subject to all liabilities and penalties provided in the said Act and Rules.
- 10. Employer's and Contractor's Risks**
- 10.1 The Employer carries the risks which this Contract states are Employer's risks, and the Contractor carries the risks which this Contract states are Contractor's risks.
- 11. Employer's Risks**
- 11.1 From the Start Date until the Defects Liability Certificate has been issued, the following are Employer's risks:

-
- (a) The risk of personal injury, death, or loss of or damage to property (excluding the Works, Plant, Materials, and Equipment), which are due to
 - (i) use or occupation of the Site by the Works or for the purpose of the Works, which is the unavoidable result of the Works or
 - (ii) negligence, breach of statutory duty, or interference with any legal right by the Employer or by any person employed by or contracted to him except the Contractor.
 - (b) The risk of damage to the Works, Plant, Materials, and Equipment to the extent that it is due to a fault of the Employer or in the Employer's design, or due to war or radioactive contamination directly affecting the country where the Works are to be executed.

11.2 From the Completion Date until the Defects Liability Certificate has been issued, the risk of loss of or damage to the Works, Plant, and Materials is an Employer's risk except loss or damage due to

- (a) a Defect which existed on the Completion Date,
- (b) an event occurring before the Completion Date, which was not itself an Employer's risk, or
- (c) the activities of the Contractor on the Site after the Completion Date.

12. Contractor's Risks

12.1 From the Starting Date until the Defects Liability Certificate has been issued, the risks of personal injury, death, and loss of or damage to property (including, without limitation, the Works, Plant, Materials, and Equipment) which are not Employer's risks are Contractor's risks.

13. Insurance

- 13.1 The Contractor shall provide, in the joint names of the Employer and the Contractor, insurance cover from the Start Date to the end of the Defects Liability Period, in the amounts and deductibles **stated in the PCC** for the following events which are due to the Contractor's risks:
- (a) loss of or damage to the Works, Plant, and Materials [which are incorporated in works];
 - (b) loss of or damage to Construction Equipment;
 - (c) loss of or damage to property (except the Works, Plant, Materials, and Equipment) in connection with the Contract; and
 - (d) personal injury or death.
- 13.2 Policies and certificates for insurance shall be delivered by the Contractor to the Project Manager for the Project Manager's approval before the Start Date. All such insurance shall provide for compensation to be payable in the types and proportions of currencies required to rectify the loss or damage incurred.
- 13.3 If the Contractor does not provide any of the policies and certificates required, the Employer may effect the insurance which the Contractor should have provided and recover the premiums the Employer has paid from payments otherwise due to the Contractor or, if no payment is due, the payment of the premiums shall be a debt due.
- 13.4 Alterations to the terms of insurance shall not be made without the approval of the Project Manager.
- 13.5 Both parties shall comply with any conditions of the insurance policies.

14. Site Data

- 14.1 The Contractor shall be deemed to have examined any Site Data **referred to in the PCC**, supplemented by any information available to the Contractor.

15. Contractor to Construct the Works including protection of environment and assurance of public health and safety

- 15.1 The Contractor shall construct and install the Works in accordance with the Specifications and Drawings and as per instructions of Project Manager.
- 15.2.1 The Contractor shall take all reasonable steps to protect the environment on and off the Site and to avoid damage or nuisance to persons or to property of the public or others resulting from pollution, noise or other cause arising as a consequence of his methods of operation.
- 15.2.2 During continuance of the contract, the contractor and his sub-contractors shall abide at all times by all existing enactments on environmental protection and rules made thereunder, regulations, notifications and by-laws of the State or Central Government, or local authorities and other law, bye-law,

-
- regulations that may be passed or notification that may be issued in this respect in future by the State or Central Government or the local authority. Salient features of the major laws are given in Appendix 1 to the General Conditions of Contract.
- 16 The Works to Be Completed by the Intended Completion Date**
- 16.1 The Contractor may commence execution of the Works on the Start Date and shall carry out the Works in accordance with the Program submitted by the Contractor, as updated with the approval of the Project Manager, and complete them by the Intended Completion Date.
- 17 Approval by the Project Manager**
- 17.1 The Contractor shall submit Specifications and Drawings showing the proposed Temporary Works to the Project Manager, for his approval.
- 17.2 The Contractor shall be responsible for design of Temporary Works.
- 17.3 The Project Manager's approval shall not alter the Contractor's responsibility for design of the Temporary Works.
- 17.4 The Contractor shall obtain approval of third parties to the design of the Temporary Works, where required.
- 17.5 All Drawings prepared by the Contractor for the execution of the temporary or permanent Works, are subject to prior approval by the Project Manager before this use.
- 18 Safety**
- 18.1 The Contractor shall be responsible for the safety of all activities on the Site.
- 19 Discoveries**
- 19.1 Anything of historical or other interest or of significant value unexpectedly discovered on the Site shall be the property of the Employer. The Contractor shall notify the Project Manager of such discoveries and carry out the Project Manager's instructions for dealing with them.
- 20 Possession of the Site**
- 20.1 The Employer shall give possession of all parts of the Site to the Contractor. If possession of a part is not given by the date **stated in the PCC**, the Employer shall be deemed to have delayed the start of the relevant activities, and this shall be a Compensation Event.
- 21 Access to the Site**
- 21.1 The Contractor shall allow the Project Manager and any person authorized by the Project Manager access to the Site and to any place where work in connection with the Contract is being carried out or is intended to be carried out.

- 22 Instructions, Inspections and Audits**
- 22.1 The Contractor shall carry out all instructions of the Project Manager which comply with the applicable laws where the Site is located.
- 22.2 The Contractor shall keep, and shall make all reasonable efforts to cause its Subcontractors and sub-consultants to keep, accurate and systematic accounts and records in respect of the Works in such form and details as will clearly identify relevant time changes and costs.
- 22.3 The Contractor shall permit and shall cause its Subcontractors and sub-consultants to permit, the Bank and/or persons appointed by the Bank to inspect the Site and/or the accounts and records relating to the performance of the Contract and the submission of the bid, and to have such accounts and records audited by auditors appointed by the Bank if requested by the Bank. The Contractor's and its Subcontractors' and sub-consultants' attention is drawn to Sub-Clause 25.1 which provides, inter alia, that acts intended to materially impede the exercise of the Bank's inspection and audit rights provided for under Sub-Clause 22.2 constitute a prohibited practice subject to contract termination (as well as to a determination of ineligibility pursuant to the Bank's prevailing sanctions procedures).
- 23 Appointment of the Adjudicator or Dispute Review Expert**
- 23.1 The Adjudicator/Dispute Review Expert [DRE] named in PCC shall be appointed jointly by the Employer and the Contractor, at the time of the Employer's issuance of the Letter of Acceptance. If, in the Letter of Acceptance, the Employer does not agree on the appointment of the Adjudicator/DRE, the Employer will request the Appointing Authority **designated in the PCC**, to appoint the Adjudicator/DRE within 14 days of receipt of such request.
- 23.1.1 The Adjudicator/DRE should be in position before "notice to proceed with work" is issued to the Contractor and an agreement should be signed with the Adjudicator/DRE jointly by the Employer and the Contractor in the form attached – Appendix 3.
- 23.2 Should the Adjudicator/DRE resign or die, or should the Employer and the Contractor agree that the Adjudicator/DRE is not functioning in accordance with the provisions of the Contract; a new Adjudicator/DRE shall be jointly appointed by the Employer and the Contractor. In case of disagreement between the Employer and the Contractor, within 30 days, the Adjudicator/DRE shall be designated by the Appointing Authority **designated in the PCC** at the request of either party, within 14 days of receipt of such request.
- 24 Procedure for Disputes**
- 24.1 If the Contractor believes that a decision taken by the Project Manager was either outside the authority given to the Project

Manager by the Contract or that the decision was wrongly taken, the decision shall be referred to the Adjudicator/DRE within 14 days of the notification of the Project Manager's decision.

- 24.2 The Adjudicator/DRE shall give a decision in writing within 28 days of receipt of a notification of a dispute.
- 24.3 The Adjudicator/DRE shall be paid daily at the rate **specified in the PCC**, together with reimbursable expenses of the types **specified in the PCC**, and the cost shall be divided equally between the Employer and the Contractor. Whatever decision is reached by the Adjudicator/DRE, either party may refer that decision to an Arbitrator within 28 days of the Adjudicator's /DRE's written decision. If neither party refers the dispute to arbitration within the above 28 days, the Adjudicator's /DRE's decision shall be final and binding.
- 24.4 The arbitration shall be conducted in accordance with the arbitration procedures published by the institution named and in the place **specified in the PCC**.

The Arbitrator(s) shall give a decision in writing within 120 days of start of the proceedings unless otherwise agreed to by the Parties. The Arbitrators shall entertain only those issues which have been earlier referred to the Adjudicator/Dispute Review Expert and either party is dissatisfied with the decision given by the Adjudicator/Dispute Review Expert.

25. Corrupt And Fraudulent Practices

- 25.1 The Bank requires compliance with its policy in regard to corrupt and fraudulent practices as set forth in Appendix to the GCC.
- 25.2 The Employer requires the Contractor to disclose any commissions or fees that may have been paid or are to be paid to agents or any other party with respect to the bidding process or execution of the Contract. The information shall be disclosed as and when such payments are made or agreed to, and compliance with the disclosure requirement shall be furnished, while submitting each monthly statement for payments; such disclosure must include at least the name and address of the agent or other party, the amount and currency, and the purpose of the commission, gratuity or fee.

B. Time Control

26. Program

- 26.1 Within the time **stated in the PCC**, after the date of the Letter of Acceptance, the Contractor shall submit to the Project Manager for approval a revised Program (revising the program given alongwith the bid) including Environmental Management Plan(to comply with the applicable Laws/ Rules/ Regulations for protection of environment, public health and safety, and the applicable parts of the Environment Management Plan of the

project) showing the general methods, arrangements, order, and timing for all the activities in the Works alongwith monthly cash flow forecasts.

- 26.2 An update of the Program shall be a program showing the actual progress achieved on each activity and the effect of the progress achieved on the timing of the remaining work, including any changes to the sequence of the activities.
- 26.3 The Contractor shall submit to the Project Manager for approval an updated Program at intervals no longer than the period **stated in the PCC**. If the Contractor does not submit an updated Program within this period, the Project Manager may withhold the amount **stated in the PCC** from the next payment certificate and continue to withhold this amount until the next payment after the date on which the overdue Program has been submitted.
- 26.4 The Project Manager's approval of the Program shall not alter the Contractor's obligations. The Contractor may revise the Program and submit it to the Project Manager again at any time. A revised Program shall show the effect of Variations and Compensation Events.
- 26.5 The Contractor shall furnish monthly progress reports as directed by the Project Manager by 7th of the succeeding month. The report shall include charts and detailed descriptions of the progress of identified activities, photographs showing status of progress at site, records of Contractor's personnel and equipment, Quality Assurance documents, comparison of actual and planned progress as per program. This report will also include progress on the ESHS Management Strategies and Implementation Plans (ESHMSIP), and compliance to the applicable Laws/ Rules/ Regulations for protection of environment, public health and safety, and the applicable parts of the Environment Management Plan of the project.

27. Extension of the Intended Completion Date

- 27.1 The Project Manager shall extend the Intended Completion Date including milestones if a Compensation Event occurs or a Variation is issued which makes it impossible for Completion to be achieved by the Intended Completion Date as per agreed milestones without the Contractor taking steps to accelerate the remaining work, which would cause the Contractor to incur additional cost.
- 27.2 The Project Manager shall decide whether and by how much to extend the Intended Completion Date/milestones within 21 days of the Contractor asking the Project Manager for a decision upon the effect of a Compensation Event or Variation and submitting full supporting information. If the Contractor has failed to give early warning of a delay or has failed to

-
- cooperate in dealing with a delay, the delay by this failure shall not be considered in assessing the new Intended Completion Date/milestones.
- 28. Acceleration**
- 28.1 When the Employer wants the Contractor to finish before the Intended Completion Date, the Project Manager shall obtain priced proposals for achieving the necessary acceleration from the Contractor. If the Employer accepts these proposals, the Intended Completion Date shall be adjusted accordingly and confirmed by both the Employer and the Contractor.
- 28.2 If the Contractor's priced proposals for acceleration are accepted by the Employer, they are incorporated in the Contract Price and treated as a Variation.
- 29. Delays Ordered by the Project Manager**
- 29.1 The Project Manager may instruct the Contractor to delay the start or progress of any activity within the Works.
- 30. Management Meetings**
- 30.1 Either the Project Manager or the Contractor may require the other to attend a management meeting. (Which will be held at the place **indicated in PCC**. The periodicity to be fixed by Project Manager / Contractor jointly). The business of a management meeting shall be to review the progress of construction with reference to the construction program given in accordance with GCC 26.1, the plans for remaining work and to deal with matters raised in accordance with the early warning procedure.
- 30.2 The Project Manager shall record the business of management meetings and provide copies of the record to those attending the meeting and to the Employer. The responsibility of the parties for actions to be taken shall be decided by the Project Manager either at the management meeting or after the management meeting and stated in writing to all who attended the meeting.
- 31. Early Warning**
- 31.1 The Contractor shall warn the Project Manager at the earliest opportunity of specific likely future events or circumstances that may adversely affect the quality of the work, increase the Contract Price, or delay the execution of the Works. The Project Manager may require the Contractor to provide an estimate of the expected effect of the future event or circumstance on the Contract Price and Completion Date. The estimate shall be provided by the Contractor as soon as reasonably possible.
- 31.2 The Contractor shall cooperate with the Project Manager in making and considering proposals for how the effect of such an event or circumstance can be avoided or reduced by anyone involved in the work and in carrying out any resulting instruction of the Project Manager.

C. Quality Control

- 32. Quality Assurance**
- 32.1 The Contractor shall institute Quality Assurance (QA) and Quality Control (QC) systems in accordance with Quality Assurance Plan to demonstrate compliance with the requirements of the Contract as approved by the Project Manager.
- 32.2 Compliance with the QA/QC systems shall not relieve the Contractor of any of his duties obligations or responsibilities under the Contract.
- 33. Tests**
- 33.1 The Contractor shall provide all apparatus, assistance, documents and other information, electricity, equipment, fuel, consumables, instruments, labour, materials, and suitably qualified and experienced staff, as are necessary to carry out the specified tests efficiently.
- 33.2 If the Project Manager instructs the Contractor to carry out a test not specified in the Specification to check whether any work has a Defect and the test shows that it does, the Contractor shall pay for the test and any samples. If there is no Defect, the test shall be a Compensation Event.
- 34. Identifying and Correction of Defects**
- 34.1. The Project Manager shall check the Contractor's work and notify the Contractor of any defects that are found specifying a time by which it should be corrected. Such checking shall not affect the Contractor's responsibilities. The Project Manager may instruct the Contractor to search for a Defect and to uncover and test any work that the Project Manager considers may have a Defect.
- 34.2 The contractor shall permit the Employer's Technical auditor to check the contractor's work and notify the Project Manager and Contractor of any defects that are found. Such a check shall not affect the Contractor's or the Project Manager's responsibility as defined in the Contract Agreement
- 34.3 The Project Manager shall give notice to the Contractor of any Defects [specifying a time limit by which it should be corrected] before the end of the Defects Liability Period, which begins at Completion, and is **defined in the PCC**. The Defects Liability Period shall be extended for as long as Defects remain to be corrected.
- 34.4 Every time notice of a Defect is given, the Contractor shall correct the notified Defect within the length of time specified by the Project Manager's notice.
- 35. Uncorrected Defects**
- 35.1 If the Contractor has not corrected a Defect within the time specified in the Project Manager's notice, the Project Manager shall assess the cost of having the Defect corrected and the Contractor shall pay this amount.

Note: 1. Where in certain cases, the technical specifications provide for acceptance of works within specified tolerance limits at reduced rates, Project Manager will certify payments to Contractor accordingly.

2. Where the failure to correct a particular defect within the specified time is considered as a fundamental breach of contract a notice should be given to the contractor as stated in GCC 57.2(e).

D. Cost Control

- 36. Contract Price** 36.1 The Bill of Quantities shall contain priced items for the Works to be performed by the Contractor. The Bill of Quantities is used to calculate the Contract Price. The Contractor will be paid for the quantity of the work accomplished at the rate in the Bill of Quantities for each item.
- 37. Changes in the Contract Price** 37.1 If the final quantity of the work done differs from the quantity in the Bill of Quantities for the particular item by more than 25 percent, provided the change exceeds 1 percent of the Initial Contract Price, the Project Manager shall adjust the rate to allow for the change.
- (a) If the quantity of work executed exceeds the quantity of the item in BOQ beyond the higher specified limit the Project Manager shall fix the rate to be applied for the additional quantity of the work executed.
- (b) If the quantity of work executed less than the quantity of the item in BOQ lesser than the lower specified limit, the Project Manager shall fix the rate to be applied for whole of the quantity of the work so executed.
- 37.2. The Project Manager shall not adjust rates from changes in quantities if thereby the Initial Contract Price is exceeded by more than 15 percent, except with the prior approval of the Employer.
- 37.3 If requested by the Project Manager, the Contractor shall provide the Project Manager with a detailed cost breakdown of any rate in the Bill of Quantities.
- 38. Variations** 38.1 All Variations shall be included in updated Programs, produced by the Contractor.
- 38.2 The Contractor shall provide the Project Manager with a quotation (with breakdown of unit rates) for carrying out the Variation when requested to do so by the Project Manager. The Project Manager shall assess the quotation, which shall be given within seven (7) days of the request or within any longer period stated by the Project Manager and before the Variation is ordered.
- 38.3 If the work in the Variation corresponds to an item description

in the Bill of Quantities and if, in the opinion of the Project Manager, the quantity of work above the limit stated in Sub-Clause 37.1 or the timing of its execution do not cause the cost per unit of quantity to change, the rate in the Bill of Quantities shall be used to calculate the value of the Variation. If the cost per unit of quantity changes, or if the nature or timing of the work in the Variation does not correspond with items in the Bill of Quantities, the quotation by the Contractor shall be in the form of new rates for the relevant items of work.

- 38.4 If the Contractor's quotation is unreasonable, [*or if contractor fails to provide the Project Manager with a quotation within a reasonable time specified by Project Manager in accordance with GCC38.2*] the Project Manager may order the Variation and make a change to the Contract Price, which shall be based on the Project Manager's own forecast of the effects of the Variation on the Contractor's costs
- 38.5 If the Project Manager decides that the urgency of varying the work would prevent a quotation being given and considered without delaying the work, no quotation shall be given and the Variation shall be treated as a Compensation Event.
- 38.6 The Contractor shall not be entitled to additional payment for costs that could have been avoided by giving early warning.

39. Cash Flow Forecasts

- 39.1 When the Program, is updated, the Contractor shall provide the Project Manager with an updated cash flow forecast. The cash flow forecast shall be in Indian Rupees.

40. Payment Certificates

- 40.1 The Contractor shall submit to the Project Manager monthly statements of the estimated value of the work executed less the cumulative amount certified previously alongwith details of measurement of the quantity of works executed in a tabular form approved by the Project Manager.
- 40.2 The Project Manager shall check the details given in the Contractor's monthly statement and within 14 days certify the amounts to be paid to the Contractor after taking into account any credit or debit for the month in question in respect of materials for the works in the relevant amount and under conditions set forth in GCC Sub-Clause 49.4 [*Secured Advance*]
- 40.3 The value of work executed shall be determined by the Project Manager after due check measurement of the quantities claimed as executed by the contractor
- 40.4 The value of work executed shall comprise of the value of the quantities of work in the Bill of Quantities that have been completed;
- 40.5 The value of work executed shall include the valuation of

Variations and Compensation Events.

- 40.6 The Project Manager may exclude any item certified in a previous certificate or reduce the proportion of any item previously certified in any certificate in the light of later information.
- 41. Payments**
- 41.1 Payments shall be adjusted for deductions for advance payments, retention, other recoveries in terms of contract & taxes to be deducted at source [TDS] as per applicable law. The Employer shall pay the Contractor the amounts certified by the Project Manager within 28 days of the date of each certificate. If the Employer makes a late payment, the Contractor shall be paid interest on the late payment in the next payment. Interest shall be calculated from the date by which the payment should have been made upto the date when the late payment is made at the rate **stated in the PCC**.
- 41.2 If an amount certified is increased in a later certificate or as a result of an award by the Adjudicator/DRE or an Arbitrator, the Contractor shall be paid interest upon the delayed payment as set out in this clause. Interest shall be calculated at the rate stated in GCC 41.1 above, from the date upon which the increased amount would have been certified in the absence of dispute.
- 41.3 Items of the Works for which no rate or price has been entered in shall not be paid for by the Employer and shall be deemed covered by other rates and prices in the Contract.
- 42. Compensation Events**
- 42.1 The following shall be Compensation Events:
- (a) The Employer does not give access to a part of the Site by the Site Possession Date pursuant to GCC Sub-Clause 20.1.
 - (b) The Employer modifies the Schedule of Other Contractors in a way that affects the work of the Contractor under the Contract.
 - (c) The Project Manager orders a delay or does not issue Drawings, Specifications, or instructions required for execution of the Works on time.
 - (d) The Project Manager instructs the Contractor to uncover or to carry out additional tests upon work, which is then found to have no Defects.
 - (e) The Project Manager unreasonably does not approve a subcontract to be let.
 - (f) Ground conditions are substantially more adverse than could reasonably have been assumed before issuance of the Letter of Acceptance from the information issued to bidders (including the Site Investigation Reports), from information available publicly and from a visual inspection of the Site.

- (g) The Project Manager gives an instruction for dealing with an unforeseen condition, caused by the Employer, or additional work required for safety or other reasons.
- (h) Other contractors, public authorities, utilities, or the Employer does not work within the dates and other constraints stated in the Contract, and they cause delay or extra cost to the Contractor.
- (i) The advance payment is delayed.
- (j) The effects on the Contractor of any of the Employer's Risks.
- (k) The Project Manager unreasonably delays issuing a Certificate of Completion.

42.2 If a Compensation Event would cause additional cost or would prevent the work being completed before the Intended Completion Date, the Contract Price shall be increased and/or the Intended Completion Date shall be extended. The Project Manager shall decide whether and by how much the Contract Price shall be increased and whether and by how much the Intended Completion Date shall be extended.

42.3 As soon as information demonstrating the effect of each Compensation Event upon the Contractor's forecast cost has been provided by the Contractor, it shall be assessed by the Project Manager, and the Contract Price shall be adjusted accordingly. If the Contractor's forecast is deemed unreasonable, the Project Manager shall adjust the Contract Price based on the Project Manager's own forecast. The Project Manager shall assume that the Contractor shall react competently and promptly to the event.

42.4 The Contractor shall not be entitled to compensation to the extent that the Employer's interests are adversely affected by the Contractor's not having given early warning or not having cooperated with the Project Manager.

43. Tax

43.1 The rates quoted by the Contractor shall be deemed to be inclusive of the GST and other payable taxes that the Contractor will have to pay for the performance of this Contract. The Employer will perform such duties in regard to the deduction of such taxes at source [TDS] as per applicable law.

43.2 The Project Manager shall adjust the Contract Price if taxes, duties, and other levies are changed between the deadline for the submission of bids for the Contract and the date of the last Completion certificate. The adjustment shall be the change in the amount of tax payable by the Contractor, provided such changes are not already reflected in the Contract Price.

-
- 44.Currencies** 44.1 All payments shall be made in Indian Rupees.
- 45. Price Adjustment** 45.1 As completion period of the works is less than 18 months, so the Contract price is treated as fixed price. In the case when the works would stop due to the reason beyond the control of the Contractor for a time more than double of contract period, then the Contract price shall be adjusted for increase or decrease in rates and price of labour, materials, fuels and lubricants and other inputs to the works in accordance with the principles and procedures outlined below. A table of adjustment data is **included in the PCC** which indicates the coefficients of various inputs and the sources of indices for various schedules of BOQ. If the PCC does not include a table of adjustment data this sub clause shall not apply and there shall be no price adjustment.
- (a) The price adjustment according to sub para (d) below, shall apply for the work done from the start date given in the PCC upto the end of the Intended Completion Date. If there is delay in completion beyond such date for reasons attributable to the contractor, the Price Adjustment for the work carried out during such period, for reasons attributable to the Contractor, shall be regulated by sub-para (g) below.
- (b) The Contract Price shall be adjusted to take account of any increase or decrease in cost after the base date, which affect the Contractor in performance of obligations under the Contract.
- (c) The total value (R) of the work done during the specified period[GCC 40.1]shall be as under:

$$R = \text{SUM} (R_{S1} + R_{S2} + R_{S3} + \dots R_{Sn}),$$
Where,
‘R_{sn}’ is the value of work done during the specified period to which the price adjustment shall be applied for the relevant schedule of Bill of Quantities (BOQ) specified in **PCC** during the specified period, and represented as under:

$$R_{sn} = (V_{sn} + S_{sn}) \text{ minus (amount of secured advance recovered in the same period + value of works executed under variations for which price adjustments will be worked separately based on terms mutually agreed between the Project Manager and the Contractor)}$$
where,
V_{sn} is the total value of work done during the specified period for the respective schedule of BOQ, and
S_{sn} is the secured advance paid during the specified

period for the respective schedule of BOQ,

- (d) The adjustment to be applied to the amount otherwise payable to the Contractor, as valued in accordance with the appropriate schedule of BOQ and certified in Payment Certificates, shall be determined from formulae which shall be of the following general type:

$$P_n = a + b L_n/L_o + c E_n/E_o + d M_n/M_o + \dots\dots\dots$$

where,

“P_n” is the adjustment multiplier to be applied to the value of the work done during the period “n”, this period being a month unless otherwise stated in the PCC.

“a” is a fixed coefficient, stated in the relevant table of adjustment data, representing the non-adjustable portion in contractual payments;

“b”, “c”, “d”,... are coefficients representing the estimated proportion of each cost element related to the execution of the Works, as stated in the relevant table of adjustment data; such tabulated cost elements may be indicative of resources such as labour, equipment and materials;

“L_n”[Labour], “E_n”[Equipment], “M_n”[Material], are the current cost indices or reference prices for period “n”, each of which is applicable to the relevant tabulated cost element [Labour, Equipment, Steel, Cement, Fuel/Lubricants, Bitumen, others] on the date, specified in the Table-2 of Adjustment Data, prior to the last day of the period (to which the particular Payment Certificate relates); and

“L_o”, “E_o”, “M_o”, are the base cost indices or reference prices, expressed in the relevant currency of payment, each of which is applicable to the relevant tabulated cost element on the Base Date.

- (e) The cost indices or reference prices stated in the tables of adjustment data given in PCC shall be used. The base date shall be the deadline for the submission of bids.
- (f) If the Contractor fails to complete the Works within the Intended Completion date, adjustment of prices thereafter shall be made using either:
- (i) index or price applicable for each cost element tabulated in the tables of adjustment data on the specified date prior to the expiry of the Intended

Completion Date, or

- (ii) the current index or price applicable for the period in question whichever is more favourable to the Employer.
- (g) The weightings (coefficients) for each of the factors of cost stated in the table(s) of adjustment data shall only be varied by the Project Manager if they have been rendered unreasonable, unbalanced or inapplicable, as a result of Variations.
- (h) Unless otherwise **stated in the P.C.C.**, the Price adjustment shall be done in each monthly Interim Payment Certificate [IPC]. The coefficients and indices are given in the Tables of Adjustment Data in Contract data.

To the extent that full compensation for any rise or fall in costs to the contractor is not covered by the provisions of this or other clauses in the contract, the unit rates and prices included in the contract shall be deemed to include amounts to cover the contingency of such other rise or fall in costs

46. Retention

- 46.1 The Employer shall retain from each payment due to the Contractor the proportion **stated in the PCC** until Completion of the whole of the Works
- 46.2 Upon the issue of a Certificate of Completion of the Works by the Project Manager, in accordance with GCC 53.1, half the total amount retained shall be repaid to the Contractor and half when the Defects Liability Period has passed and the Project Manager has certified that all Defects notified by the Project Manager to the Contractor before the end of this period have been corrected. On completion of the whole works the Contractor may substitute the balance retention money with an “on demand” Bank guarantee.

47. Liquidated Damages

- 47.1 The Contractor shall pay liquidated damages to the Employer at the rate per day **stated in the PCC** for each day that the Completion Date is later than the Intended Completion Date (for the whole of the works or the milestones as stated in the PCC). The total amount of liquidated damages shall not exceed the amount **defined in the PCC**. The Employer may deduct liquidated damages from payments due to the Contractor. Payment of liquidated damages shall not affect the Contractor’s liabilities.

Time is the essence of the contract and payment or deduction of liquidated damages shall not relieve the contractor from his obligation to complete the work as per agreed construction program and milestones, or from any of the Contractor’s

other obligations and liabilities under the contract.

- 47.2 If the Intended Completion Date including milestones is extended after liquidated damages have been paid, the Project Manager shall correct any overpayment of liquidated damages by the Contractor by adjusting the next payment certificate. The Contractor shall be paid interest on the overpayment, calculated from the date of payment to the date of repayment, at the rates specified in GCC Sub-Clause 41.1.

48. Bonus

- 48.1 Not used.

49. Advance Payment

- 49.1 The Employer shall make advance payment to the Contractor of the amounts **stated in the PCC** by the date **stated in the PCC**, against provision by the Contractor of an Unconditional Bank Guarantee in a form and by a bank acceptable to the Employer in amounts in Indian Rupees equal to the advance payment. The Guarantee shall remain effective until the advance payment has been repaid, but the amount of the Guarantee shall be progressively (*each instalment not less than Rs. 500,000*) reduced by the amounts repaid by the Contractor. Interest shall not be charged on the advance payment.

- 49.2 The Contractor is to use the advance payment only to pay for Equipment, Plant, Materials, and mobilization expenses required specifically for execution of the Contract. The Contractor shall demonstrate that advance payment has been used in this way by supplying copies of invoices or other documents to the Project Manager.

- 49.3 The advance payment shall be repaid by deducting proportionate amounts from payments otherwise due to the Contractor, following the schedule of completed percentages of the Works on a payment basis. No account shall be taken of the advance payment or its repayment in assessing valuations of work done, Variations, price adjustments, Compensation Events, Liquidated Damages.

Secured Advances

- 49.4 The Project Manager shall make advance payment in respect of materials intended for but not yet incorporated in the Works in accordance with conditions **stipulated in the PCC**.

50. Securities

- 50.1 The Performance Security shall be provided to the Employer no later than the date specified in the Letter of Acceptance and shall be issued in an amount **specified in the PCC**, by a Nationalized or Schedule bank in India, and denominated. The Bank Guarantee for Performance Security and additional security for unbalanced bids shall be valid until a date 28 days from the date of issue of the Certificate of Completion.

51. Dayworks	51.1	Not used.
52. Cost of Repairs	52.1	Loss or damage to the Works or Materials to be incorporated in the Works between the Start Date and the end of the Defects Correction periods shall be remedied by the Contractor at the Contractor's cost if the loss or damage arises from the Contractor's acts or omissions.

E. Finishing the Contract

53. Completion	53.1	The Contractor shall request the Project Manager to issue a Certificate of Completion of the Works, and the Project Manager shall do so upon deciding that the whole of the Works is completed.
54. Taking Over	54.1	The Employer shall take over the Site and the Works within seven days of the Project Manager's issuing a certificate of Completion.
55. Final Account	55.1	The Contractor shall supply the Project Manager with a detailed account of the total amount that the Contractor considers payable under the Contract at the end of the Defects Liability Period. The Project Manager shall issue a Defects Liability Certificate and certify any final payment that is due to the Contractor within 56 days of receiving the Contractor's account if it is correct and complete. If it is not, the Project Manager shall issue within 56 days a schedule that states the scope of the corrections or additions that are necessary including corrections and additions to comply with the applicable Laws/ Rules/ Regulations for protection of environment, public health and safety, and the applicable parts of the Environment Management Plan of the project. If the Final Account is still unsatisfactory after it has been resubmitted, the Project Manager shall decide on the amount payable to the Contractor and issue a payment certificate within 56 days of receiving the contractor's revised account.
56. Operating and Maintenance Manuals	56.1	If "as built" Drawings [including a compact disk containing digitized drawings] and/or operating and maintenance manuals are required, the Contractor shall supply them by the dates stated in the PCC .
	56.2	If the Contractor does not supply the Drawings [including a compact disk containing digitized drawings] and/or manuals by the dates stated in the PCC pursuant to GCC Sub-Clause 56.1, or they do not receive the Project Manager's approval, the Project Manager shall withhold the amount stated in the PCC from payments due to the Contractor.
57. Termination	57.1	The Employer or the Contractor may terminate the Contract if the other party causes a fundamental breach of the Contract

after giving fourteen (14) days written notice.

57.2 Fundamental breaches of Contract shall include, but shall not be limited to, the following:

- (a) the Contractor stops work for 28 days when no stoppage of work is shown on the current Program and the stoppage has not been authorized by the Project Manager;
- (b) the Project Manager instructs the Contractor to delay the progress of the Works, and the instruction is not withdrawn within 28 days;
- (c) the Employer or the Contractor is made bankrupt or goes into liquidation other than for a reconstruction or amalgamation;
- (d) a payment certified by the Project Manager is not paid by the Employer to the Contractor within 84 days of the date of the Project Manager's certificate;
- (e) the Project Manager gives Notice that failure to correct a particular Defect is a fundamental breach of Contract and the Contractor fails to correct it within a reasonable period of time determined by the Project Manager;
- (f) the Contractor does not maintain a Security, which is required;
- (g) the Contractor has delayed the completion of the Works by the number of days for which the maximum amount of liquidated damages can be paid, as **defined in the PCC**; or
- (h) if the Contractor, in the judgment of the Employer, has engaged in corrupt or fraudulent practices in competing for or in executing the Contract, pursuant to GCC Clause 25.1, then the Employer may, after giving fourteen (14) days written notice to the Contractor, terminate the Contract and expel him from the Site.
- (i) The contractor has contravened Clauses 7 and 9 of GCC.
- (j) The contractor does not adhere to the agreed construction program and agreed environmental management plan [Clause 26 of GCC] and also fails to take satisfactory remedial action as per agreements reached in the management meetings [Clause 30 of GCC] for a period of 60 days.
- (k) The contractor fails to carry out of the instructions of the Project Manager within a reasonable time determined by the Project Manager in accordance with GCC Clause 15.1 and 22.
- (l) The contractor (in case of Joint Venture) has modified the composition of the joint venture and/or the responsibility of each member of the joint venture from what is stated in joint venture agreement without the prior approval of the

Employer.

- 57.3 When either party to the Contract gives notice of a breach of Contract to the Project Manager for a cause other than those listed under GCC Sub-Clause 57.2 above, the Project Manager shall decide whether the breach is fundamental or not.
- 57.4 Notwithstanding the above, the Employer may terminate the Contract for convenience.
- 57.5 If the Contract is terminated, the Contractor shall stop work immediately, make the Site safe and secure, and leave the Site as soon as reasonably possible.
- 58.Payment upon Termination**
- 58.1 If the Contract is terminated because of a fundamental breach of Contract by the Contractor, the Project Manager shall issue a certificate for the value of the work done and Materials ordered less advance payments received upto the date of the issue of the certificate less other recoveries due in terms of contract, less taxes to be deducted at source [TDS] as per applicable law, and less the percentage to apply to the value of the work not completed, as **indicated in the PCC**. Additional Liquidated Damages shall not apply. If the total amount due to the Employer exceeds any payment due to the Contractor, the difference shall be a debt payable to the Employer.
- 58.2 If the Contract is terminated for the Employer's convenience or because of a fundamental breach of Contract by the Employer, the Project Manager shall issue a certificate for the value of the work done, Materials ordered, the reasonable cost of removal of Equipment, repatriation of the Contractor's personnel employed solely on the Works, and the Contractor's costs of protecting and securing the Works, and less advance payments received upto the date of the certificate less other recoveries due in terms of the contract and less taxes due to be deducted at source [TDS] as per applicable law.
- 59.Property**
- 59.1 All Materials on the Site, Plant, Equipment, Temporary Works, and Works shall be deemed to be the property of the Employer if the Contract is terminated because of the Contractor's default.
- 60.Release from Performance**
- 60.1 If the Contract is frustrated by the outbreak of war or by any other event entirely outside the control of either the Employer or the Contractor, the Project Manager shall certify that the Contract has been frustrated. The Contractor shall make the Site safe and stop work as quickly as possible after receiving this certificate and shall be paid for all work carried out before receiving it and for any work carried out afterwards to which a commitment was made.

**61.Suspension of
Bank Loan or
Credit**

- 61.1 In the event that the Bank suspends the Loan or Credit to the Employer, from which part of the payments to the Contractor are being made:
- (a) The Employer is obligated to notify the Contractor of such suspension within 7 days of having received the Bank's suspension notice.
 - (b) If the Contractor has not received sums due it within the 28 days for payment provided for in Sub-Clause 40.1, the Contractor may immediately issue a 14-day termination notice.

APPENDIX TO GENERAL CONDITIONS

Bank's Policy- Corrupt and Fraudulent Practices

(Text in this Appendix shall not be modified)

Guidelines for Procurement of Goods, Works, and Non-Consulting Services under IBRD Loans and IDA Credits & Grants by World Bank Borrowers, dated January 2011:

“Fraud and Corruption:

1.16 It is the Bank's policy to require that Borrowers (including beneficiaries of Bank loans), bidders, suppliers, contractors and their agents (whether declared or not), sub-contractors, sub-consultants, service providers or suppliers, and any personnel thereof, observe the highest standard of ethics during the procurement and execution of Bank-financed contracts.²⁴ In pursuance of this policy, the Bank:

- (a) defines, for the purposes of this provision, the terms set forth below as follows:
 - (i) “corrupt practice” is the offering, giving, receiving, or soliciting, directly or indirectly, of anything of value to influence improperly the actions of another party;²⁵
 - (ii) “fraudulent practice” is any act or omission, including a misrepresentation, that knowingly or recklessly misleads, or attempts to mislead, a party to obtain a financial or other benefit or to avoid an obligation;²⁶
 - (iii) “collusive practice” is an arrangement between two or more parties designed to achieve an improper purpose, including to influence improperly the actions of another party;²⁷
 - (iv) “coercive practice” is impairing or harming, or threatening to impair or harm, directly or indirectly, any party or the property of the party to influence improperly the actions of a party;²⁸
 - (v) “obstructive practice” is
 - (aa) deliberately destroying, falsifying, altering, or concealing of evidence material to the investigation or making false statements

²⁴In this context, any action to influence the procurement process or contract execution for undue advantage is improper.

²⁵ For the purpose of this sub-paragraph, “another party” refers to a public official acting in relation to the procurement process or contract execution. In this context, “public official” includes World Bank staff and employees of other organizations taking or reviewing procurement decisions.

²⁶ For the purpose of this sub-paragraph, “party” refers to a public official; the terms “benefit” and “obligation” relate to the procurement process or contract execution; and the “act or omission” is intended to influence the procurement process or contract execution.

²⁷ For the purpose of this sub-paragraph, “parties” refers to participants in the procurement process (including public officials) attempting either themselves, or through another person or entity not participating in the procurement or selection process, to simulate competition or to establish bid prices at artificial, non-competitive levels, or are privy to each other's bid prices or other conditions.

²⁸ For the purpose of this sub-paragraph, “party” refers to a participant in the procurement process or contract execution.

to investigators in order to materially impede a Bank investigation into allegations of a corrupt, fraudulent, coercive or collusive practice; and/or threatening, harassing or intimidating any party to prevent it from disclosing its knowledge of matters relevant to the investigation or from pursuing the investigation, or

- (bb) acts intended to materially impede the exercise of the Bank's inspection and audit rights provided for under paragraph 1.16(e) below.
- (b) will reject a proposal for award if it determines that the bidder recommended for award, or any of its personnel, or its agents, or its sub-consultants, sub-contractors, service providers, suppliers and/or their employees, has, directly or indirectly, engaged in corrupt, fraudulent, collusive, coercive, or obstructive practices in competing for the contract in question;
- (c) will declare mis-procurement and cancel the portion of the loan allocated to a contract if it determines at any time that representatives of the Borrower or of a recipient of any part of the proceeds of the loan engaged in corrupt, fraudulent, collusive, coercive, or obstructive practices during the procurement or the implementation of the contract in question, without the Borrower having taken timely and appropriate action satisfactory to the Bank to address such practices when they occur, including by failing to inform the Bank in a timely manner at the time they knew of the practices;
- (d) will sanction a firm or individual, at any time, in accordance with the prevailing Bank's sanctions procedures,²⁹ including by publicly declaring such firm or individual ineligible, either indefinitely or for a stated period of time: (i) to be awarded a Bank-financed contract; and (ii) to be a nominated³⁰;
- (e) will require that a clause be included in bidding documents and in contracts financed by a Bank loan, requiring bidders, suppliers and contractors, and their sub-contractors, agents, personnel, consultants, service providers, or suppliers, to permit the Bank to inspect all accounts, records, and other documents relating to the submission of bids and contract performance, and to have them audited by auditors appointed by the Bank."

²⁹ A firm or individual may be declared ineligible to be awarded a Bank financed contract upon: (i) completion of the Bank's sanctions proceedings as per its sanctions procedures, including, inter alia, cross-debarment as agreed with other International Financial Institutions, including Multilateral Development Banks, and through the application the World Bank Group corporate administrative procurement sanctions procedures for fraud and corruption; and (ii) as a result of temporary suspension or early temporary suspension in connection with an ongoing sanctions proceeding. See footnote 14 and paragraph 8 of Appendix 1 of these Guidelines.

³⁰ A nominated sub-contractor, consultant, manufacturer or supplier, or service provider (different names are used depending on the particular bidding document) is one which has either been: (i) included by the bidder in its pre-qualification application or bid because it brings specific and critical experience and know-how that allow the bidder to meet the qualification requirements for the particular bid; or (ii) appointed by the Borrower.

Section IX. Particular Conditions of Contract

A. General													
GCC 1.1 (d)	The financing institution is: International Bank for Reconstruction and Development (IBRD) (<i>World Bank</i>) & Government of India												
GCC 1.1 (r)	The Employer is: <i>Superintending Engineer, Research Circle, Irrigation Research Institute, Roorkee- 247667</i>												
GCC 1.1 (v)	The Intended Completion Date for the whole of the Works shall be <i>9 months from the date of award.</i>												
GCC 1.1 (y)	The Project Manager is <i>Executive Engineer, State Project Monitoring Unit, NHP, IRI, Roorkee.</i>												
GCC 1.1 (aa)	The Site is located at: as per the list attached in five district of Uttarakhand state.												
GCC 1.1 (dd)	The Start Date shall be one week after the date of issue of notice to proceed with works to the contractor.												
GCC 1.1 (hh)	<p>The Works consist of Drilling and installation of 66 nos groundwater monitoring wells and construction of 66 nos. Protection works for DWLR telemetry system to monitor groundwater level and quality under National Hydrology Project (NHP) in Uttarakhand State</p> <p>Identification number of Contract is 11/SE(R)/NHP/e-Tender/2020-21 dated 09.04.2021</p>												
GCC 2.2	Sectional Completions are: <i>NA</i>												
GCC 2.3(i)	<p>The following documents also form part of the Contract: <i>[list documents]</i></p> <table border="1" style="width: 100%; border-collapse: collapse;"> <thead> <tr> <th style="width: 10%;">S.No.</th> <th style="width: 30%;">Document</th> <th style="width: 60%;">Description of the document</th> </tr> </thead> <tbody> <tr> <td style="text-align: center;">1.</td> <td>Construction Methodology</td> <td>Construction methodology given in bid amended as per comments of Employer given in letter of acceptance.</td> </tr> <tr> <td style="text-align: center;">2.</td> <td>Quality control</td> <td>Quality control procedures and assurance plans given in the bid and amended as per comments of Employer given in letter of acceptance.</td> </tr> <tr> <td style="text-align: center;">3.</td> <td>Environmental, Social, Health and Safety</td> <td>(i) ESHS Management Strategies and Implementation Plans; (ii) Labor Influx and Worker's Camp Management Plan including the process for mitigating construction related impacts</td> </tr> </tbody> </table>	S.No.	Document	Description of the document	1.	Construction Methodology	Construction methodology given in bid amended as per comments of Employer given in letter of acceptance.	2.	Quality control	Quality control procedures and assurance plans given in the bid and amended as per comments of Employer given in letter of acceptance.	3.	Environmental, Social, Health and Safety	(i) ESHS Management Strategies and Implementation Plans; (ii) Labor Influx and Worker's Camp Management Plan including the process for mitigating construction related impacts
S.No.	Document	Description of the document											
1.	Construction Methodology	Construction methodology given in bid amended as per comments of Employer given in letter of acceptance.											
2.	Quality control	Quality control procedures and assurance plans given in the bid and amended as per comments of Employer given in letter of acceptance.											
3.	Environmental, Social, Health and Safety	(i) ESHS Management Strategies and Implementation Plans; (ii) Labor Influx and Worker's Camp Management Plan including the process for mitigating construction related impacts											

			on local community; and (iii) Code of Conduct that will apply to its employees and subcontractors, to ensure compliance with its Environmental, Social, Health and Safety (ESHS) obligations under the contract.																												
GCC 3.1	The language of the contract is <i>English</i> . The law that applies to the Contract is the laws of Union of India.																														
GCC 5.1	The Project manager may delegate any of his duties and responsibilities.																														
GCC 7.1	The ceiling for sub-contractor is Nil																														
GCC 8.1	Schedule of other contractors: <i>NA</i>																														
GCC 9.1	<p>Key Personnel and equipment:</p> <p>GCC 9.1 is replaced with the following: Key Personnel are the Contractor's personnel named in this GCC 9.1 of the Particular Conditions of Contract. The Contractor shall employ the Key Personnel and use the equipment identified in its Bid, to carry out the Works or other personnel and equipment approved by the Project Manager. The Project Manager shall approve any proposed replacement of Key Personnel and equipment only if their relevant qualifications or characteristics are substantially equal to or better than those proposed in the Bid.</p> <p><i>[insert the name/s of each Key Personnel agreed by the Employer prior to Contract signature, Schedule of Key Personnel and equipment as indicated in accepted bid & construction methodology].</i></p>																														
GCC 13.1	The minimum insurance amounts and deductibles shall be:																														
	<table border="1"> <thead> <tr> <th>S.No.</th> <th>Description</th> <th>Minimum cover for Insurance</th> <th>Maximum deductible for Insurance</th> </tr> </thead> <tbody> <tr> <td>(i)</td> <td>Works and Plant and Materials which are incorporated in works</td> <td>Equivalent to the cost of contract</td> <td>1% of the Contract Price.</td> </tr> <tr> <td>(ii)</td> <td>Loss or damage to Construction Equipment</td> <td>INR 50 lacs</td> <td>INR 50000/</td> </tr> <tr> <td>(iii)</td> <td>Other Property</td> <td>INR 10 lacs</td> <td>INR 10000/</td> </tr> <tr> <td>(iv)</td> <td>Personal injury or death insurance:</td> <td>INR 10 lakhs per incident</td> <td>INR 10000/ each</td> </tr> <tr> <td></td> <td>a) for other people;</td> <td></td> <td></td> </tr> <tr> <td></td> <td>b) for Contractor's Employees</td> <td colspan="2">In accordance with the statutory requirements applicable in India</td> </tr> </tbody> </table>	S.No.	Description	Minimum cover for Insurance	Maximum deductible for Insurance	(i)	Works and Plant and Materials which are incorporated in works	Equivalent to the cost of contract	1% of the Contract Price.	(ii)	Loss or damage to Construction Equipment	INR 50 lacs	INR 50000/	(iii)	Other Property	INR 10 lacs	INR 10000/	(iv)	Personal injury or death insurance:	INR 10 lakhs per incident	INR 10000/ each		a) for other people;				b) for Contractor's Employees	In accordance with the statutory requirements applicable in India			
S.No.	Description	Minimum cover for Insurance	Maximum deductible for Insurance																												
(i)	Works and Plant and Materials which are incorporated in works	Equivalent to the cost of contract	1% of the Contract Price.																												
(ii)	Loss or damage to Construction Equipment	INR 50 lacs	INR 50000/																												
(iii)	Other Property	INR 10 lacs	INR 10000/																												
(iv)	Personal injury or death insurance:	INR 10 lakhs per incident	INR 10000/ each																												
	a) for other people;																														
	b) for Contractor's Employees	In accordance with the statutory requirements applicable in India																													
GCC 14.1	Site Data are: Sheet attached																														
GCC 15.2	15.2.2 (b): The Contractor shall implement all mitigation measures for which responsibility is assigned to him as stipulated in the Environmental																														

	Management <i>Framework</i> , and the conditions stipulated in Section VII-Work Requirements of this Bidding Document, even if not explicitly covered under the ESHS-MSIP submitted by the bidder and made part of the Contract Document.
GCC 20.1	The Site Possession Date(s) shall be: notified by employer The Site Possession Dates shall be: Section 1 One Week after issuing of Work Order Section 2 One Week after issuing of Work Order
GCC 23.1 & GCC 23.2	Name of the agreed Adjudicator/Dispute Review Expert: Shri Rajendra Chalisgaonkar, Engineer-in-Chief (Retd.), Irrigation Department, Govt. of Uttarakhand. Appointing Authority for the Adjudicator/Dispute Review Expert: <i>Secretary/ Principle Secretary of Uttarakhand.</i>
GCC 24.3	Daily rate and types of reimbursable expenses to be paid to the Adjudicator/Dispute Review Expert: Rs 5000 per day. The reimbursable expenses e.g travel and boarding/lodging payable to the Adjudicator will be governed by the rules of Uttarakhand State.
GCC 24.4	The procedure for adhoc arbitration will be as follows: (a) In case of Dispute or difference arising between the Employer and an Indian Contractor relating to any matter arising out of or connected with this agreement, such disputes or difference shall be settled in accordance with the Arbitration and Conciliation Act, 1996 as amended up-to-date. The arbitral tribunal shall consist of 3 Arbitrators one each to be appointed by the Employer and the Contractor. The third Arbitrator shall be chosen by the two Arbitrators so appointed by the Parties and shall act as Presiding Arbitrator. In case of failure of the two Arbitrators appointed by the parties to reach upon a consensus within a period of 30 days from the appointment of the Arbitrator appointed subsequently, the Presiding Arbitrator shall be appointed by the / President of the Institution of Engineers (India)/.For the purposes of this Sub-Clause, the term “Indian Contractor” means a contractor who is registered in India and is a juridic person created under Indian law as well as a joint venture between such a contractor and a Foreign Contractor. Note: [Sub-para (b) is applicable in case of contract award to foreign contractors]. (b) In the case of dispute with a Foreign Contractor the dispute shall be settled in accordance with provisions of UNCITRAL Arbitration Rules. The Arbitral Tribunal shall consist of three

	<p>Arbitrators one each to be appointed by the Employer and the Contractor. The third Arbitrator shall be chosen by the two Arbitrators so appointed by the Parties, and shall act a presiding Arbitrator. In case of failure of the two Arbitrators appointed by the parties to reach upon a consensus within a period of 30 days from the appointment of the Arbitrator appointed, the Presiding Arbitrator shall be appointed by the /President of the Institution of Engineers (India)/.For the purposes of this Clause, the term “Foreign Contractor” means a contractor who is not registered in India and is not a juridical person created under Indian Law.</p> <p>(c) If one of the parties fails to appoint its Arbitrator in pursuance of sub-clause (a) and (b) above within 30 days after receipt of the notice of the appointment of its Arbitrator by the other party, then the Indian Council of Arbitration, both in cases of Foreign Contractor as well as Indian Contractor, shall appoint the Arbitrator. A certified copy of the order of the Indian Council of Arbitration, making such an appointment shall be furnished to each of the parties.</p> <p>(d) Arbitration may be commenced prior to or after completion of the Works, provided that the obligations of the Employer, the Project Manager, the Contractor and the Adjudicator/ Dispute Review Expert shall not be altered by reason of the arbitration being conducted during the progress of the Works.</p> <p>(e) Arbitration proceedings shall be held at Roorkee, India, and the language of the arbitration proceedings and that of all documents and communications between the parties shall be English.</p> <p>(f) The decision of the majority of Arbitrators shall be final and binding upon both parties. The cost and expenses of Arbitration proceedings will be paid as determined by the arbitral tribunal. However, the expenses incurred by each party in connection with the preparation, presentation, etc. of its proceedings as also the fees and expenses paid to the Arbitrator appointed by such party or on its behalf shall be borne by each party itself.</p> <p>(g) Where the value of the contract is Rs. 50 million and below, the disputes or differences arising shall be referred to the Sole Arbitrator. The Sole Arbitrator should be appointed by agreement between the parties; failing such agreement, by the appointing authority, namely the Indian Council of Arbitration.</p> <p>(h) The Arbitrator should give final award within 180 days of starting of the proceedings [<i>indicate the days (Between 120-180) by which arbitrator should give award</i>].</p> <p>(i) Performance under the contract shall continue during the arbitration proceedings and payments due to the contractor by the Employer shall not be withheld, unless they are the subject</p>
--	---

	<p>matter of the arbitration proceedings.</p> <p>The arbitral tribunal shall consist of 3 Arbitrators, arbitration proceedings shall be held at Roorkee, India and the language of the arbitration proceedings and that of all documents and communications between the parties shall be English”. <i>[ICA rules provide for arbitration tribunal of 3 arbitrators if the value of claim is over Rs 1 crore unless the parties have agreed otherwise for a sole arbitrator].</i></p>
B. Time Control	
GCC 26.1	The Contractor shall submit a revised Program including Environmental Management Plan and ESHS-MSIP for the Works (in such form and detail as the Project Manager shall reasonably prescribe) within 14 days of delivery of the Letter of Acceptance.
GCC 26.3	<p>The period between Program updates is 30 days.</p> <p>The amount to be withheld for late submission of an updated Program is Rs-10% of value of related work(s).</p>
GCC 26.6	<p>The following is inserted as a new sub clause 26.6:</p> <p>“26.6 The contractor will submit a brief Labor Influx and Worker’s Camp Management Plan including the process for mitigating construction related impacts on local community within 30 days of signing the contract. The plan shall be updated and a revised plan shall be submitted, if required.”</p>
GCC 30	Venue of management meeting will be Employer Office at IRI, Roorkee, in general, or as fixed by the Employer as per convenient.
C. Quality Control	
GCC 34.3	The Defects Liability Period is: 365 days.
D. Cost Control	
GCC 41.1	Interest rate for Delayed payment is 2% per annum.
GCC 43.1	<p>Replace GCC 43.1 with the following:</p> <p>The rates quoted by the Contractor shall be deemed to be exclusive of the GST that the Contractor will have to pay for the performance of this Contract. The Employer will perform such duties in regard to the deduction of such taxes at source [TDS] as per applicable law.</p> <p>Payment of Local taxes such as GST shall be made as per prevailing Acts & rules against valid Tax invoice and submission of valid GST registration certificate along with declaration that GST registration is valid and all liabilities towards GST against the agreement has been discharged by the contractor. GST shall be paid after 30 days of submission of valid invoice</p>

	<p>and all other required documents and declaration by contractor.</p> <p>(i) “GST” means all four acts CGST, SGST, UTGST, IGST and any other regulations by Government in relation to GST and Rules thereto.</p> <p>The Income Tax, CASs, other deductions and surcharges, if applicable, will be deducted from the payments due to the supplier.</p>								
GCC 45.1	<p>Price Adjustment:</p> <p>The contract is not subject to price adjustment.</p>								
GCC 46.1	<p>The proportion of payments retained (Retention Money) shall be 5% from each bill subject to the maximum of 5% of final contract price until defect liability period has been passed.</p>								
GCC 47.1	<p>The liquidated damages for the whole of the Works 0.15% per day. The maximum amount of liquidated damages for the whole of the Works is 10% of the final Contract Price.</p> <table> <tr> <td>For milestone 1</td> <td>Rs. 0.2% per day</td> </tr> <tr> <td>For milestone 2</td> <td>Rs. 0.1% per day</td> </tr> <tr> <td>For milestone 3</td> <td>Rs. 0.1% per day</td> </tr> <tr> <td>All works</td> <td>Rs. 0.15% per day</td> </tr> </table>	For milestone 1	Rs. 0.2% per day	For milestone 2	Rs. 0.1% per day	For milestone 3	Rs. 0.1% per day	All works	Rs. 0.15% per day
For milestone 1	Rs. 0.2% per day								
For milestone 2	Rs. 0.1% per day								
For milestone 3	Rs. 0.1% per day								
All works	Rs. 0.15% per day								
GCC 49.1	<p>No Advance payment will be made.</p>								
GCC 50.1	<p>“GCC 50.1 is replaced with the following</p> <p>The Performance Security and an Environmental, Social, Safety and Health (ESHS) Performance Security shall be provided to the Employer no later than the date specified in the Letter of Acceptance and shall be issued in the amounts specified in the PCC (for GCC 50.1), and shall be issued by a Nationalized or Scheduled bank in India. The Performance Security and the ESHS Performance Security, shall be valid until a date 28 days from the date of issue of the Certificate of Completion.”</p>								
GCC 50.1	<p>The Performance Security amount is 10 percent of contract price plus 1% percent of Contract Amount as additional security for unbalanced bids [<i>in terms of ITB Clause 40</i>], and Environmental, Social, Safety and Health (ESHS) Performance Security amount is 1% percent of Contract Amount.</p> <p>The standard form of Performance Security acceptable to the Employer shall be <u>unconditional</u> Bank Guarantees from a Scheduled or Nationalized banks in India of the types as presented in Section X of the Bidding Documents.</p> <p><i>Note: Throughout this bidding document the term ‘performance security’, unless the context clearly indicates otherwise, means and includes both ‘the performance security and the ESHS performance security’ to be submitted</i></p>								

	<i>by the successful bidder in the amounts specified above.</i>
E. Finishing the Contract	
GCC 56.1	<p>* The date by which operating and maintenance manuals are required is within 28 days of issue of certificate of completion of whole or section of work, as the case may be[insert date]</p> <p>* The date by which “as-built” drawings (in scale...) including a compact disc containing digitized drawings in 2 sets are required is within 28 days of issue of certificate of completion of whole or section of the work, as the case may be[insert date].</p>
GCC 56.2	The amount to be withheld for failing to produce “as built” drawings and/or operating and maintenance manuals *by the date required in G.C.C. 56.1 is Rs. 2.5 lakhs.
GCC 57.2 (g)	The maximum number of days is:365 days
GCC 58.1	The percentage to apply to the value of the work not completed, representing the Employer’s additional cost for completing the Works, is 20%.

Appendices

Appendix 1

Salient Features of Labour & Environment Protection Laws³¹

SALIENT FEATURES OF SOME MAJOR LABOUR LAWS APPLICABLE TO ESTABLISHMENTS ENGAGED IN BUILDING AND OTHER CONSTRUCTION WORK

- | | |
|---|--|
| <ul style="list-style-type: none"> (a) (b) (c) (d) (e) (f) (g) (h) (i) | <p><u>Employees Compensation Act 1923</u>: The Act provides for compensation in case of injury, disease or death arising out of and during the course of employment.</p> <p><u>Payment of Gratuity Act 1972</u>: gratuity is payable to an employee under the Act on satisfaction of certain conditions on separation if an employee has completed 5 years' service or more or on death at the rate of 15 days wages for every completed year of service. The Act is applicable to all establishments employing 10 or more employees.</p> <p><u>Employees P.F. and Miscellaneous Provision Act 1952 (since amended)</u>: The Act provides for monthly contribution by the employer plus workers @ 10% or 8.33%. The benefits payable under the Act are:</p> <ul style="list-style-type: none"> (i) Pension or family pension on retirement or death, as the case may be. (ii) Deposit linked insurance on the death in harness of the worker. (iii) Payment of P.F. accumulation on retirement/death etc. <p><u>Maternity Benefit Act 1961</u>: The Act provides for leave and some other benefits to women employees in case of confinement or miscarriage etc.</p> <p><u>Sexual Harassment of Women at the Workplace (Prevention, Prohibition and Redressal) Act, 2013</u>: This Act defines sexual harassment in the workplace, provides for an enquiry procedure in case of complaints and mandates the setting up of an Internal Complaints Committee or a Local Complaints Committee</p> <p><u>Contract Labour (Regulation & Abolition) Act 1970</u>: The Act provides for certain welfare measures to be provided by the Contractor to contract labour and in case the Contractor fails to provide, the same are required to be provided, by the Principal Employer by law. The Principal Employer is required to take Certificate of Registration and the Contractor is required to take license from the designated Officer. The Act is applicable to the establishments or Contractor of Principal Employer if they employ 20 or more contract labour.</p> <p><u>Minimum Wages Act 1948</u>: The Employer is supposed to pay not less than the Minimum Wages fixed by appropriate Government as per provisions of the Act if the employment is a scheduled employment. Construction of Buildings, Roads, Runways are scheduled employments.</p> <p><u>Payment of Wages Act 1936</u>: It lays down the mode, manner and by what date the wages are to be paid, what deductions can be made from the wages of the workers.</p> <p><u>Equal Remuneration Act 1976</u>: The Act provides for payment of equal wages for</p> |
|---|--|

³¹This list is only illustrative and not exhaustive. Bidders and Contractors are responsible for checking the correctness and completeness of the list. The law as current on the date of bid opening will apply.

work of equal nature to male and female workers and for not making discrimination against Female employees in the matters of transfers, training and promotions etc.

- (j) Payment of Bonus Act 1965: The Act is applicable to all establishments employing 20 or more employees. Some of the State Governments have reduced this requirement from 20 to 10. The Act provides for payments of annual bonus subject to a minimum of 8.33% of the wages drawn in the relevant year. It applies to skilled or unskilled manual, supervisory, managerial, administrative, technical or clerical work for hire or reward to employees who draw a salary of Rs. 10,000/- per month or less. To be eligible for bonus, the employee should have worked in the establishment for not less than 30 working days in the relevant year. The Act does not apply to certain establishments.
- (k) Industrial Disputes Act 1947: the Act lays down the machinery and procedure for resolution of Industrial disputes, in what situations, a strike or lock-out becomes illegal and what are the requirements for laying off or retrenching the employees or closing down the establishment.
- (l) Trade Unions Act 1926: The Act lays down the procedure for registration of trade unions of workmen and employers. The Trade Unions registered under the Act have been given certain immunities from civil and criminal liabilities.
- (m) Child Labour (Prohibition & Regulation) Act 1986: The Act prohibits employment of children below 14 years of age in certain occupations and processes and provides for regulation of employment of children in all other occupations and processes. Employment of Child Labour is prohibited in the Building and Construction Industry.
- (n) Inter-State Migrant workmen's (Regulation of Employment & Conditions of Service) Act 1979: The Act is applicable to an establishment which employs 5 or more inter-state migrant workmen through an intermediary (who has recruited workmen in one state for employment in the establishment situated in another state). The Inter-State migrant workmen, in an establishment to which this Act becomes applicable, are required to be provided certain facilities such as housing, medical aid, traveling expenses from home upto the establishment and back, etc.
- (o) The Building and Other Construction Workers (Regulation of Employment and Conditions of Service) Act 1996 and the Building and Other Construction Workers Welfare Cess Act, 1996 (BOCWW Cess Act): All the establishments who carry on any building or other construction work and employ 10 or more workers are covered under these Acts. All such establishments are required to pay cess at the rate not exceeding 2% of the cost of construction as may be notified by the Government. The Employer of the establishment is required to provide safety measures at the building or construction work and other welfare measures, such as Canteens, First –Aid facilities, Ambulance, Housing accommodations for workers near the work place etc. The Employer to whom the Act applies has to obtain a registration certificate from the Registering Officer appointed by the Government.
- (p) Factories Act 1948: the Act lays down the procedure for approval of plans before setting up a factory engaged in manufacturing processes, health and safety provisions, welfare provisions, working hours, annual earned leave and rendering information regarding accidents or dangerous occurrences to designated authorities. It is applicable to premises employing 10 persons or more with aid of

- power or 20 or more persons without the aid of power.
- (q) Weekly Holidays Act -1942
 - (r) Bonded Labour System (Abolition) Act, 1976: The Act provides for the abolition of bonded labour system with a view to preventing the economic and physical exploitation of weaker sections of society. Bonded labour covers all forms of forced labour, including that arising out of a loan, debt or advance.
 - (s) Employer's Liability Act, 1938: This Act protects workmen who bring suits for damages against employers in case of injuries endured in the course of employment. Such injuries could be on account of negligence on the part of the employer or persons employed by them in maintenance of all machinery, equipment etc. in healthy and sound condition.
 - (t) Employees State Insurance Act 1948: The Act provides for certain benefits to insured employees and their families in case of sickness, maternity and disablement arising out of an employment injury. The Act applies to all employees in factories (as defined) or establishments which may be so notified by the appropriate Government. The Act provides for the setting up of an Employees' State Insurance Fund, which is to be administered by the Employees State Insurance Corporation. Contributions to the Fund are paid by the employer and the employee at rates as prescribed by the Central Government. The Act also provides for benefits to dependents of insured persons in case of death as a result of an employment injury.
 - (u) The Personal Injuries (Compensation Insurance) Act, 1963: This Act provides for the employer's liability and responsibility to pay compensation to employees where workmen sustain personal injuries in the course of employment.
 - (v) Industrial Employment (Standing Order) Act 1946: It is applicable to all establishments employing 100 or more workmen (employment size reduced by some of the States and Central Government to 50). The Act provides for laying down rules governing the conditions of employment by the Employer on matters provided in the Act and get the same certified by the designated Authority.

SALIENT FEATURES OF SOME OF THE MAJOR LAWS THAT ARE APPLICABLE FOR PROTECTION OF ENVIRONMENT.

1. The Environment (Protection) Act, 1986 and as amended: This provides for the protection and improvement of environment and for matters connected therewith, and the prevention of hazards to human beings, other living creatures, plants and property. 'Environment' includes water, air and land and the inter-relationship which exists among and between water, air and land, and human beings, other living creatures, plants, micro-organism and property.
2. The Forest Conservation Act, 1980, as amended, and Forest (Conservation) Rules, 1981 as amended: These provides for protection of forests by restricting conversion of forested areas into non- forested areas and prevention of deforestation, and stipulates the procedures for cutting any trees that might be required by the applicable rules. Permissions under the Act also stipulates the norms and compliance requirements of the employer and any contractor on behalf of the employer.
3. State Tree Preservation Acts as may be in force: These provide for protection of trees of important species. Contractors will be required to obtain prior permission for full or partial cutting, uprooting, or pruning of any such trees.
4. The Wildlife (Protection) Act, 1972, and as amended: This provides for protection of wildlife through notifying National Parks and Sanctuaries and buffer areas around these zones; and to protect individuals of nationally important species listed in the Annex of the Act.
5. The Biological Diversity Act, 2002: This provides for conservation of biological diversity, sustainable use of components of biological diversity, and fair and equitable sharing of the benefits arising out of the use of biological resources, knowledge and for matters connected therewith or incidental thereto.
6. The Public Liability Insurance Act, 1991 as amended and The Public Liability Insurance Rules, 1991 as amended: These provide for public liability insurance for the purpose of providing immediate relief to the persons affected by accident occurring while handling hazardous substances and for mattes connected herewith or incidental thereto. Hazardous substance means any substance or preparation which is defined as hazardous substance under the Environment (Protection) Act 1986, and exceeding such quantity as may be specified by notification by the Central Government.
7. The Ancient Monuments and Archaeological Sites and Remains Act, 1958 and the Ancient Monuments and Archaeological Sites and Remains (Amendment and Validation) Act, 2010, the Ancient Monuments and Archaeological Sites and Remains Rules, 1959 amended 2011, the National Monuments Authority Rules, 2011 and the similar State Acts: These provide for conservation of cultural and historical remains found in India. Accordingly, area within the radii of 100m and 300m from the "protected property" are designated as "protected area" and "controlled area" respectively. No development activity (including building, mining, excavating, blasting) is permitted in the "protected area" and development activities likely to damage the protected property is not permitted in the "controlled area" without prior permission of the Archaeological Survey of India (ASI) or the State Departments of Art and Culture or Archaeology as applicable.

8. The Environmental Impact Assessment Notification, 2006 and as amended: This provides for prior environmental clearance for new, modernization and expansion projects listed in Schedule 1 of the Notification. Contractors will be required to ensure that no work starts until applicable clearances under the Notification is not available. Contractors will be responsible for implementation of any environmental management plan stipulated as per the permission under this Notification; and will be required to prepare and submit to the employer and compliance report stipulated in the permission under the Notification.
9. The Water (Prevention and Control of Pollution) Act, 1974 as amended, and the Water (Prevention and Control of Pollution) Rules, 1975 as amended: These provide for the prevention and control of water pollution and the maintaining and restoring of wholesomeness of water. 'Pollution' means such contamination of water or such alteration of the physical, chemical or biological properties of water or such discharge of any sewage or trade effluent or of any other liquid, gaseous or solid substance into water (whether directly or indirectly) as may, or is likely to, create a nuisance or render such water harmful or injurious to public health or safety, or to domestic, commercial, industrial, agricultural or other legitimate uses, or to the life and health of animals or plants or of aquatic organisms. Contractors will need to obtain consent for establishment and consent for operation of any item of work or installation of equipment that generates waste water, and observe the required standards of establishment and operation of these items of work or installations; as well as install and operate all required waste water treatment facilities.
10. The Water (Prevention and Control of Pollution) Cess Act, 1977 and The Water (Prevention and Control of Pollution) Cess Rules, 1978: These provide for the levy and collection of a cess on water consumed by persons carrying on certain industries and by local authorities, with a view to augment the resources of the Central Board and the State Boards for the prevention and control of water pollution under the Water (Prevention and Control of Pollution) Act, 1974.
11. The Air (Prevention and Control of Pollution) Act, 1981 as amended, and the Air (Prevention and Control of Pollution) Rules, 1982: These provides for prevention, control and abatement of air pollution. 'Air Pollution' means the presence in the atmosphere of any 'air pollutant', which means any solid, liquid or gaseous substance (including noise) present in the atmosphere in such concentration as may be or tend to be injurious to human beings or other living creatures or plants or property or environment. Contractors will need to obtain consent for establishment and consent for operation of any item of work or installation of equipment that generates air pollution such as batching plants, hot mix plants, power generators, backup power generation, material handling processes, and observe the required standards of establishment and operation of these items of work or installations.
12. Noise Pollution (Control and Regulation) Rules, 2000, and as amended: This provides for standards for noise for day and night for various land uses and specifies special standards in and around sensitive receptors of noise such as schools and hospitals. Contractors will need to ensure compliance to the applicable standards, and install and operate all required noise control devices as may be required for all plants and work processes.
13. Chemical Accidents (Emergency Planning, Preparedness and Response) Rules, 1996: This provides for Requirement of preparation of on-site and off-site Disaster Management Plans for accident-prone areas.

14. The Explosives Act 1884 and the Explosives Rules, 2008: These provide for safe manufacture, possession, sale, use, transportation and import of explosive materials such as diesel, Oil and lubricants etc.; and also for regulating the use of any explosives used in blasting and/or demolition. All applicable provisions will need compliance by the contractors.
15. The Petroleum Rules, 2002: This provides for safe use and storage of petroleum products, and will need to be complied by the contractors.
16. The Gas Cylinder Rules 2004 and amendments: This provides for regulations related to storage of gas, and possession of gas cylinder more than the exempted quantity. Contractors should comply with all the requirements of this Rule.
17. Manufacture, Storage and Import of Hazardous Chemical Rules of 1989 and as amended: These provide for use and storage of hazardous material such as highly inflammable liquids like HSD/LPG. Contractors will need to ensure compliance to the Rules; and in the event where the storage quantity exceeds the regulated threshold limit, the contractors will be responsible for regular safety audits and other reporting requirements as prescribed in the Rules.
18. Hazardous & Other Wastes (Management and Transboundary Movement) Rules, 2016: These provide for protection of general public from improper handling storage and disposal of hazardous waste. The rules prescribe the management requirement of hazardous wastes from its generation to final disposal. Contractors will need to obtain permission from the State Pollution Control Boards and other designated authorities for storage and handling of any hazardous material; and will to ensure full compliance to these rules and any conditions imposed in the permit.
19. The Bio Medical Waste Management Rules, 2016: This provides for control, storage, transportation and disposal of bio-medical wastes. As and where the contractor has any first aid facility and dispensaries, established in either temporary or permanent manner, compliance to these Rules are mandatory.
20. Construction and Demolition Waste Management Rules, 2016: This provides for management of construction and demolition waste (such as building materials possible to be reused, rubble and debris or the like); and applies to all those waste resulting from construction, re-modelling, repair or demolition of any civil structure. Contractor will need to prepare a waste disposal plan and obtain required approval from local authorities, if waste generation is more than 20 tons in any day or 300 tons in any month during the contract period; and ensure full compliance to these rules and any conditions imposed in the regulatory approval.
21. The E-Waste (Management) Rules, 2016: This provides for management of E-wastes (but not covering lead acid batteries and radio-active wastes) aiming to enable the recovery and/or reuse of useful material from e-waste, thereby reducing the hazardous wastes destined for disposal and to ensure the environmentally sound management of all types of waste of electrical and electronic equipment. This Rule applies to every manufacturer, producer, consumer, bulk consumer, collection centers, dealers, e-retailer, refurbisher, dismantler and

recycler involved in manufacture, sale, transfer, purchase, collection, storage and processing of e-waste or electrical and electronic equipment listed in Schedule I, including their components, consumables, parts and spares which make the product operational.

22. Plastic waste Management Rules, 2016: This provides for control and management of the plastic waste generated from any activity. Contractors will ensure compliance to this Rule.
23. The Batteries (Management and Handling) Rules 2001: This provides for ensuring safe disposal and recycling of discarded lead acid batteries likely to be used in any equipment during construction and operation stage. Rules require proper control and record keeping on the sale or import of lead acid batteries and recollection of the used batteries by registered recyclers to ensure environmentally sound recycling of used batteries. Contractors will ensure compliance to this Rule.
24. The Ozone Depleting Substances (Regulation and Control) Rules, 2000 and as amended: This provides for regulation of production and consumption of ozone depleting substances in the country, and specifically prohibits export to or import from countries not specified in the Rules, and prohibits unless specifically permitted, any use of ozone depleting substance.
25. The Coastal Regulation Zone Notifications, 1991 and as amended: This provides for regulation of development activities within the 500m of high tide line in coastal zone and 100m of stretches of rivers and estuaries influenced by tides. Contractors will be required to ensure that no work starts until applicable clearances under the Notification is not available. Contractors will be responsible for implementation of any plan stipulated as per the permission under this Notification; and will be required to prepare and submit to the employer and compliance report stipulated in the permission under the Notification.
26. The Motor Vehicle Act 1988 as amended (and State Motor Vehicle Acts as may be in force) and the Motor Vehicle Rules, 1989, and as amended (and State Motor Vehicle Rules as may be in force): To minimize the road accidents, penalizing the guilty, provision of compensation to victim and family and check vehicular air and noise pollution. Contractors will be required to ensure full compliance to these rules.
27. Easement Act, 1882: This provides for the rights of landowners on groundwater. Contractors will need to ensure that other landowners' rights under the Act is not affected by any groundwater abstraction by the contractors.
28. State Groundwater Acts and Rules as may be in force and the Guidelines for Groundwater Abstraction for drinking and domestic purposes in Notified Areas and Industry/Infrastructure project proposals in Non-Notified areas, 2012: These provide for regulating extraction of ground water for construction/industrial and drinking and domestic purposes. Contractors will need to obtain permission from Central/State Groundwater Boards prior to groundwater abstraction through digging any bore well or through any other means; and will to ensure full compliance to these rules and any conditions imposed in the permit.
29. The Mines Act, 1952 as amended; the Minor Mineral and concession Rules as amended; and the State Mineral (Rights and Taxation) Acts as may be in force: These provide for for safe and sound mining activity. The contractors will procure aggregates and other building

materials from quarries and borrow areas approved under such Acts. In the event the contractors open any new quarry and/or borrow areas, appropriate prior permission from the State Departments of Minerals and Geology will need to be obtained. Contractors will also need to ensure full compliance to these rules and any conditions imposed in the permit.

30. The Insecticides Act, 1968 and Insecticides Rules, 1971 and as amended: These provide for regulates the manufacture, sale, transport, distribution, export, import and use of pesticides to prevent risk to human beings or animals, and for matters connected therewith. No one should import or manufacture; sell, stock or exhibit foe sale; distribute, transport, use: (i) any misbranded insecticides, (ii) any insecticide the sale, distribution or use of which is for the time being prohibited under the Act; and (iii) any insecticide except in accordance with the condition on which it was registered under the Act.
31. National Building Codes of India, 2005 and as amended: This provides guidelines for regulating the building construction activities in India. The code mainly contains administrative regulations, development control rules and general building requirements; stipulations regarding materials, structural design and construction; and building and plumbing services. Contractors will be required to comply with all Bureau of Indian Standards Codes dealing with: (i) use and disposal of asbestos containing materials in construction; (ii) paints containing lead; (iii) permanent and temporary ventilations in workplace; (iv) safety, and hygiene at the workplace; (v) prevention of fire; (vi) prevention of accidents from faulty electrical gadgets, equipment and accessories; and all other such codes incidental to the Contract.

Appendix 2

GUIDELINES FOR ENVIRONMENT, SOCIAL, HEALTH AND SAFETY MANAGEMENT STRATEGIES AND IMPLEMENTATION PLANS FOR CONSTRUCTION WORKS UNDER NATIONAL HYDROLOGY PROJECT

Contents

<u>1.</u>	<u>General Requirements</u>	161
<u>2.</u>	<u>Non-permissible Activities</u>	161
<u>3.</u>	<u>Permits</u>	161
<u>4.</u>	<u>Construction Materials Management (including Hazardous Substances)</u>	PAGEREF
	<u>_Toc26886205 \h</u>	163
<u>5.</u>	<u>Management of Construction & Demolition Wastes and Hazardous Wastes</u>	164
<u>6.</u>	<u>Construction Camp Management</u>	166
<u>7.</u>	<u>Worker Health and Safety</u>	PAGEREF _Toc26886208 \h 169
<u>8.</u>	<u>Site Drainage Management</u>	172
<u>9.</u>	<u>Top Soil Management</u>	173
<u>10.</u>	<u>Air Quality Management</u>	PAGEREF _Toc26886211 \h 174
<u>11.</u>	<u>Noise and Vibration Management</u>	176
<u>12.</u>	<u>Protection of Flora</u>	PAGEREF _Toc26886213 \h 178
<u>13.</u>	<u>Protection of Fauna</u>	179
<u>14.</u>	<u>Road Transport and Road Traffic Management</u>	181
<u>15.</u>	<u>Cultural and Religious Issues</u>	182

1. General Requirements

The Contractor shall take all precautions for safeguarding the environment during the construction of works. S/He shall abide by all rules, regulations and laws in force governing pollution and environmental protection that are applicable to the area where the works are situated as per Environment, Social, Health and Safety Management Strategies and Implementation Plans (ESHS-MSIP).

All construction material including aggregates, timber, etc., shall be procured from authorized quarries and vendors. The information on the authorized quarries and vendors shall be shared with Project Manager during mobilization period as well as during construction.

All sites including labour camp, camp office, construction site, etc., shall be restored to their original condition, if not improved, on completion of works.

ESHS-MSIP Implementation Arrangements:

- The Contractor, and his Sub-Contractors, has the responsibility of establishing and maintaining contact with the Project Manager and keeping him informed of construction activities likely to affect local environmental and social conditions. This may include regular and frequent reporting and attendance at meetings at the request of the Project Manager. The Contractor and any agents or Sub-Contractors will be contractually required to comply with the requirements as specified in the Code of Conduct and Contractor's ESHS-MSIP.
- The Contractor will be responsible for adherence to Code of Conduct and implementation of the Contractor's ESHS-MSIP, including workplace safety, and will ensure adequate resources throughout the project implementation period.

Each implementing contractor will appoint an Environment, Health and Safety (EHS) qualified person having qualification and experience as indicated in the bid document who will primary be responsible for compliance of workers EHS aspects at camp as well as work site. S/He will also be responsible for implementation of EHS measures for different kind of allied project activities like material transportation, vehicular movement and etc. Summary of EHS compliance and monitoring report shall also be included with "Monthly compliance and monitoring report on ESHS-MSIP implementation" submitted by contractors to the project manager.

2. Non-permissible Activities

- Any activity that involves use of Asbestos Containing Materials (e.g., AC pipes for irrigation, AC sheets for roof). Asbestos containing material shall not be used in any construction related activity
- Any activity that violates the provisions of applicable National and State laws.

3. Permits

Guidance on permits, and clearances for various works is presented here. However, certain requirements may vary from State to State. State Project Management Unit (SPMU) is hence advised to update the clearance/ permit requirements and standards applicable for the works.

The following NOCs, but not limited to, are required to be submitted by the Contractor within 30 days of signing of Contract.

**No Objection Certificates (NoC) for Work/ Activities
(to be obtained before initiating respective activities)**

S. No.	NoC Requirement	Department for NoC	Responsible Agency
1	NoC for Water Source	Water Resource Department/ Water Authority, Ground Water Board, or Irrigation Department (as applicable) of corresponding State depending on jurisdiction.	Contractor
2	NoC for Electricity	Electricity Board/ Department	IA
3	NoC for Forest Land/ Tree Cutting	Forest Department	IA
4	Shifting of Utilities	Concerned Departments	IA
5	NoC for water abstraction	Groundwater Authority	IA
6	Use of Diesel Generator sets at any stage during project cycle.	State Pollution Control Board	Contractor
7	Permission for temporary traffic diversions, hindrances	Traffic Management Organisation	IA
8	Pollution under Control (PUC) for Vehicle	Transport Department	Contractor
9	Plants such as Crushers and/ or Batching Plants	State Pollution Control Board	Contractor
10	Storage, handling and transport of hazardous material(s)	State Pollution Control Board	Contractor

11	Location/ layout of workers' camp, equipment and storage yards	State Pollution Control Board	Contractor
12	Discharges from Labour Camp	State Pollution Control Board	Contractor
13	Permission for sand mining from river bed	State Pollution Control Board/ Forest Department	Contractor

Consents and Licences to be Obtained

- As per Water (Prevention and Control of Pollution) Cess Act, 1977; and The Air (Prevention and Control of Pollution) Act, 1981, three types of consents are to be obtained as applicable.
 - I. Consent to Establish
 - II. Consent to Operate
 - III. Renewal of Consent to Operate
- As per Contract Labour (Regulation & Abolition) Central Rules, 1971, Labour license is required from the Department of Labour.
- As per the Inter-State Migrant Workmen (Regulation of Employment and Conditions of Service) Act, 1979, the Contractor who employs or who employed five or more Inter-State migrant workmen needs to register and obtain interstate workmen migrant license from Department of Labour.
- As per Petroleum Rules, 2002 Petroleum and Explosives Safety Organisation, the Contractor to obtain NoC for transportation and storage of diesel, oil and lubricants etc.
- As per Building and Other Construction Workers (Regulation of Employment and Conditions of Service) Act, 1996, for building and other construction work, the Contractor needs to register within 60 days from commencement of work with Department of Labour.

4. Construction Materials Management (including Hazardous Substances)

Construction Materials may be a source of contamination if not properly managed. Improper storage and handling of fuels, lubricants, chemicals and hazardous goods/ materials on-site may harm the environment and may endanger the health and safety of construction workers and host communities.

The Contractor shall

- Not practice any illegal mining of sand, stone, timber etc. and water extraction (unless permitted) from nearby locations

-
- Source all raw materials (sand, stone, timber etc.) from authentic and approved vendors, possessing valid permits/receipts etc. Relevant supporting documents should be presented for scrutiny on request.
 - Ensure safe and covered stockpiling of the construction materials in separate place or a corner in the premises of building. Stockpiled materials should be covered to control dust emissions.
 - Be responsible for sourcing water. Minimum quantity of water should be used to meet the essential construction requirements. The contractor should avoid wastage of water during construction. Required permissions should be taken for extraction or use of water from local sources.
 - ensure that fuel storage at site is minimum and re-fueling is arranged at nearby pumps;
 - train the relevant construction personnel in handling of fuels and spill control procedures;
 - provide appropriate fire-fighting equipment adjacent to the storage area;
 - provide protective clothing, safety boots, helmets, masks, gloves, goggles, to the construction personnel, appropriate to materials in use;

5. Management of Construction & Demolition Wastes and Hazardous Wastes

Construction & Demolition (C&D) wastes and Hazardous wastes occupy available site space and hinder with safe movement of workers in and around the site. If not properly managed in designated sites, this often ends up in pristine environmental resources like wetlands, agricultural fields, and paddy fields. It is important to guide the storage, and reuse of construction wastes. It is also important to guide the storage and movement of hazardous waste for proper sanitary disposal.

The Contractor shall

- inventorize the waste streams expected from the project site (e.g., reusable waste, flammable waste, construction debris, food waste etc.) prior to commencing of construction and submit a management plan to Project Manager for approval. The plan shall follow all applicable rules;
- shall segregate the waste, if generated 20 tons or more in one day or 300 tons per project in a month, into four streams such as concrete, soil, steel, wood and plastics, bricks and mortar and shall submit waste management plan and get appropriate approvals from the local authority before starting construction or demolition or remodelling work and keep the concerned authorities informed regarding the relevant activities from the planning stage to the implementation stage and this should be on project to project basis. Waste generators who generate 20 tons or more in one day or 300 tons per project in a month shall have to pay for the processing and disposal of construction and demolition waste generated by them, apart from the payment for storage, collection and transportation. The rate shall be fixed by the concerned local authority or any other authority designated by the State Government;

Storage of Wastes

- It is important to segregate the wastes at source and store them in separate well labelled and well confined areas. Safe storage is essential; broken parts shall not lie around the storage area. Adequate caution/ signboards shall be provided.

-
- Provide separately labeled refuse containers at each worksite, separate for different waste streams.
 - Contract conditions shall give preference to suppliers who deliver materials without packaging or buy back packaging as per EPR,
 - Construction site and surrounds shall follow good housekeeping practices. No wastes shall be allowed to spill around and cause traffic disturbances or environmental risks.

Transport

- Transport shall be in covered vehicles, without allowing spillovers on to roads.

Disposal

- Disposal Sites: *IA needs to list the disposal sites for each type of waste*
- Disposal of wastes shall be in an environmentally acceptable way, as per applicable rules. C&D waste shall be sent to a facility where it is reused/ recycled. The generator shall arrange to deposit it in the facility/ collection area/ dumping area suggested by the local body (eg: State Pollution Control boards/Municipal Corporation).
- Small amount of wet waste (if any) from the site shall be preferably converted into compost using bin composting technique and compost can be used for nurseries or green belt.
- To follow 4 Rs – Recover, Reduce, Recycle, Reuse; best would be to follow ‘zero waste’ approach by reusing all wastes within the premise.
- To prohibit burning of solid waste.
- To train and instruct all personnel in waste management practices and procedures,
- Entrust the site environmental engineer with the responsibility to take stock of waste situation every morning when work commences and evening at work closeout. It would be a good practice to keep a record of material and waste (type-wise quantities) movements in and out of the site.
- **Hazardous** Paints, pigments, flammable liquids, or mixture of liquids, or liquids containing solids in solution or suspension solvents, spent solvents, lacquer, varnishes), cement, glue, resins, textile pieces, Empty barrels/ containers/ liners contaminated with hazardous chemicals/ wastes, Contaminated cotton rags or other cleaning materials, Sludge from treatment of waste water arising out of cleaning/ disposal of barrels/ containers, Chemical sludge from wastewater treatment, Oil and grease, chromium sludge from cooling water etc are typical hazardous wastes easily found in all construction sites. Certain types of batteries, electrical electronic wastes, wires, electric conduits, bituminous materials can also turn hazardous in certain circumstances. Examples of construction waste that are classified as hazardous include lead, tars, adhesives, sealants, asbestos. Hazardous chemicals used in construction are materials with transdermal effects, carcinogens, embryotoxic, mutagens, and neurotoxins including solvents, primers, and adhesives, wood dust, plastic woods, sealing agents, wood protectants, insulation, and products used for structural engineering.
- In India, the management of Hazardous Wastes is governed by Hazardous and Other Wastes (Management and Transboundary Movement) Rules, 2016.8

-
- The Contractor shall
 - follow the following steps, namely:
 - (a) prevention,
 - (b) minimization,
 - (c) reuse,
 - (d) recycling;
 - (e) recovery, utilization including co-processing, and
 - (f) safe disposal;

6. Construction Camp Management

Siting and Location of Construction Camps

Campsites for construction workers are the important locations that have significant impacts such as health and safety hazards on local resources and infrastructure of nearby communities.

The Contractor shall

- locate the construction camps at areas which are acceptable from environmental, cultural or social point of view;
- consider the location of construction camps away from communities in order to avoid social conflict in using the natural resources such as water or to avoid the possible adverse impacts of the construction camps on the surrounding communities;
- submit to the Project Manager for approval a detailed layout plan for the development of the construction camp within 15 days of award of Contract. The Plan should include relative locations of all temporary buildings and facilities that are to be constructed together with the location of site roads, fuel storage areas (for use in power supply generators), solid waste management and dumping locations, and drainage facilities, prior to the development of the construction camps, vehicle movement.
- duly inform local authorities responsible for health, religious and security on the set up of camp facilities so as to maintain effective surveillance over public health, social and security matters.

Labour Camp Facilities

Lack of proper infrastructure facilities, such as housing, water supply and sanitation facilities will increase pressure on the local services and generate substandard living standards and health hazards.

The Contractor shall provide the plans for Labour Camp within 15 days of award of contract. The Camp shall include the following facilities:

- Adequate housing for all workers
- Safe and reliable water supply.

-
- Hygienic sanitary facilities and sewerage system. The toilets and domestic waste water will be collected through a common sewerage. Provide separate latrines and bathing places for males and females with total isolation by wall or by location. The minimum number of toilet facilities required is one toilet for every ten persons or as per local building by laws.
 - Treatment/ disposal facilities for sewerage of toilet and domestic wastes.
 - Storm water drainage facilities.
 - Paved internal roads. Shall have grass/ vegetation coverage to be made of the use of top soil that there is no dust generation from the loose/ exposed sandy surface. Pave the internal roads of at least with bricks or porous materials to suppress dusts and to work against possible muddy surface during monsoon. This will help in water penetration and recharge as well.
 - Provide child crèches for women working on large construction sites. The crèche shall have facilities for dormitory, kitchen, indoor and outdoor play area. Schools shall be attached to these crèches so that children are not deprived of education while mothers are engaged in construction work.
 - Provide in-house community/ common entertainment facilities dependence of local entertainment outlets by the construction camps to be discouraged/ prohibited to the extent possible.

Management of Wastes from Labour camps

The Contractor shall

- ensure proper collection and disposal of solid wastes within the construction camps;
- ensure waste separation by source; organic wastes in one bin and inorganic wastes in another bin at household level;
- store inorganic wastes in a safe place within the house and clear organic wastes on daily basis to waste collector. Establish waste collection, transportation and disposal systems with the manpower and equipment/ vehicles needed;
- dispose organic wastes in a designated safe place on daily basis. At the end of the day cover the organic wastes with a thin layer of sand so that flies, mosquitoes, dogs, cats, rats, are not attracted. If space is available away from water bodies, one may dig a large hole or use a bin to put organic wastes in it; take care to protect groundwater from contamination by leachate formed due to decomposition of wastes. Cover the bed of the pit with impervious layer of materials (clayey or thin concrete) to protect groundwater from contamination. Take care to prevent odour generation as well;
- locate the garbage pit/ waste disposal site min 500 m away from the residence so that peoples are not disturbed with the odour likely to be produced from anaerobic decomposition of wastes at the waste dumping places. Encompass the waste dumping place by fencing and tree plantation to prevent children from entering;
- not establish site specific landfill sites in premises. All solid waste shall be collected and removed from the work camps and disposed in waste disposal sites approved by the local body.

Fuel Supplies for Cooking Purposes

Illegal sourcing of fuel wood by construction workers will impact the natural flora and fauna

The Contractor shall

- provide fuel to the construction camps for their domestic purpose, in order to discourage them to use fuel wood or other biomass;
- made available alternative fuels like natural gas or kerosene on ration to the workforce to prevent them using biomass for cooking;
- conduct awareness campaigns to educate workers on preserving the protecting the biodiversity and wildlife of the project area, and relevant government regulations and punitive measures for wildlife protection.

Health and Hygiene

There will be a potential for diseases to be transmitted including malaria, exacerbated by inadequate health and safety practices. There will be an increased risk of work crews spreading sexually transmitted infections and HIV/ AIDS.

The Contractor shall

- provide adequate health care facilities within construction sites;
- provide first aid facility round the clock. Maintain stock of medicines in the facility and appoint fulltime designated first-aid or nurse;
- provide ambulance facility for the laborers during emergency to be transported to nearest hospitals;
- initial health screening of the labourers coming from outside areas/ migrant laborers;
- provide health camps in coordination with nearby Primary Health Centre/ Clinic;
- train all construction workers in basic sanitation and health care issues and safety matters, and on the specific hazards of their work;
- provide HIV awareness programming, including sexually transmitted infections (STI) and HIV information, education and communication for all workers on regular basis;
- complement educational interventions with easy access to condoms at campsites as well as voluntary counseling and testing;
- provide adequate drainage facilities throughout the camps to ensure that disease vectors such as stagnant water bodies and puddles do not form. Regular mosquito repellent sprays during monsoon;
- carryout short training sessions on best hygiene practices to be mandatorily participated by all workers;
- place display boards at strategic locations within the camps containing messages on best hygienic practices.

Safety for Construction Camp

Inadequate safety facilities to the construction camps may create security problems and fire hazards.

The Contractor shall

- provide appropriate security personnel (police/ home guard or private security guards) and enclosures to prevent unauthorized entry in to the camp area;
- maintain register to keep a track on a head count of persons present in the camp at any given time;
- encourage use of flameproof material for the construction of labour housing/ site office. Also, ensure that these houses/ rooms are of sound construction and capable of withstanding wind storms/ cyclones;
- provide appropriate type of fire fighting equipment suitable for the construction camps;
- display emergency contact numbers clearly and prominently at strategic places in camps, Communicate the roles and responsibilities of laborers in case of emergency in the monthly meetings with contractors;
- encourage kitchen plantations or greenery around the camp.

Site Restoration

Restoration of the construction camps to original condition requires demolition of construction camps.

The Contractor shall

- dismantle and remove from the site all facilities established within the construction camp including the perimeter fence and lockable gates at the completion of the construction work;
- dismantle camps in phases and as the work gets decreased and not wait for the entire work to be completed;
- give prior notice to the laborers before demolishing their camps/ units;
- maintain the noise levels within the national standards during demolition activities;
- hire different contractors to demolish different structures to promote recycling or reuse of demolished material;
- reuse the demolition debris to a maximum extent. Dispose remaining debris at the designated waste disposal site;
- handover the construction camps with all built facilities as it is if agreement between both parties (contractor and land-owner) has been made so;
- restore the site to its condition prior to commencement of the works or to an agreed condition with the landowner;
- not make false promises to the laborers for future employment in Operation & Maintenance (O&M) of the project.

7. Worker Health and Safety

Construction works may pose health and safety risks to the construction workers, hosts and site visitors leading to severe injuries and deaths.

The Contractor shall

- display signs across the camp site;
- Hold tool box meeting preferably once a week in order to brief workers about Safety, do's and don'ts during construction.

provide appropriate personal protection equipment (PPE) for workers, such as safety boots, helmets, masks, gloves, protective clothing, goggles, full-face eye shields, and ear protection which they would use;

Contractor should provide:

- Safety helmets and rubber gloves and boots to the laborers to avoid worksite hazards and accidents.
 - Protective footwear, goggles and clothing to all workers employed on laying of wearing coat, preparing cement mortars for brick work, concreting, painting etc.
 - Welder's protective eye-shields to workers who are engaged in welding works
 - Earplugs to workers exposed to loud noise, and workers working with jack hammer, joint cutting machines etc.
 - Gloves and masks to workers involved in mixing and handling of raw materials.
 - Any other occupation besides above shall be provided adequate protection equipment
- Arrange mechanisms to replace damaged PPEs on time;The Contractor should comply with all regulations regarding safe scaffolding, ladders, working platforms, gangway, stairwells, excavations, trenches and safe means of entry etc.
 - Contractor should install a warning device in the project area to be used to warn the workers in case of mishap/emergency.
 - Contact numbers of police, fire brigade, ambulance, police station, in-charge of monitoring agency etc. should be displayed at project site.
 - In case, the site is in built up areas then, screens made up of GI sheets shall be placed on project periphery.
 - Contractor should have the provisions of labourer's health checkup during induction, and completion (*during construction works to be decided by IA*).
 - Temporary toilet facilities and shade area for rest should be provided at/near construction sites
 - implement suitable safety standards for all workers and site visitors which shall not be less than those laid down on the international standards (e.g. International Labour Office guideline on 'Safety and Health in Construction; World Bank Group's 'Environmental Health and Safety Guidelines') and contractor's own national standards or statutory regulations, in addition to complying with the national standards;
 - provide the workers with a safe and healthy work environment, taking into account inherent risks in its particular construction activity and specific classes of hazards in the work areas;
 - safety procedures include provision of information, training and protective clothing to workers involved in hazardous operations and proper performance of their job;
 - appoint an environment, health and safety manager to look after the health and safety of the workers;
 - obtain all permits and clearances as per applicable national regulations;

-
- inform the local authorities responsible for health, religious and security duly informed before commencement of civil works and establishment of construction camps so as to maintain effective surveillance over public health, social and security matters.

The Contractor shall also provide the following facilities in the campsites to improve health and hygienic conditions as mentioned against Construction Camp Management.

- Adequate ventilation and light
- Safe and reliable water supply shall be assured. Contractor shall provide bottled drinking water facilities or good potable water to the construction workers at all the construction sites in sufficient quantities to avoid waterborne/water-related/ water-based diseases to ensure the health and hygiene of workers.
- Hygienic sanitary facilities and sewerage arrangements shall be ensured. The sullage and sewage shall be properly disposed and not allowed to flow through open drains.
- Treatment facilities for sewerage of toilet and domestic wastes
- Storm water drainage facilities
- Recreational and social facilities,
- Solid waste collection and disposal system,
- Arrangement for trainings,
- Paved internal roads,
- Security fence at least 2 m height,
- Sick bay,
- Water and sanitation facilities at the construction sites,

Lack of water and sanitation facilities at construction sites cause inconvenience to the construction workers and communities around,

The contractor shall provide normal or portable toilets at the construction sites, if about 25 people are working the whole day for a month. Location of portable facilities shall be at least 6 m away from storm drain system and surface waters. Toilets shall be septic tank modules (which are easily available) and can be disposed at Common Septage/ Sewage Treatment Plants,

Child Labour and Pregnant Labour

The Contractor shall

- not hire children of less than 14 years of age and pregnant women or women who delivered a child within 8 preceding weeks, in accordance with the National Laws

Accidents

- Lack of first aid facilities and health care facilities in the immediate vicinity will aggravate the health conditions of the victims.
- Provide health care facilities which are readily available. Appropriately equipped first-aid stations shall be easily accessible throughout the place of work.

-
- Document and report occupational accidents, diseases, and incidents,
 - Prevent accidents, injury, and disease arising from, associated with, or occurring in the course of work by minimizing, so far as reasonably practicable, the causes of hazards. In a manner consistent with good international industry practice,
 - Identify potential hazards to workers, particularly those that may be life-threatening and provide necessary preventive and protective measures,
 - Provide awareness to the construction drivers to strictly follow the driving rules,
 - Provide adequate lighting in the construction area and along the roads. In case the work site is near around sensitive areas, consult Project Manager to arrive at appropriate lighting standards.

Trainings

Lack of awareness and basic knowledge in health care among the construction workforce, make them susceptible to potential diseases.

The Contractor shall

- train all construction workers in basic sanitation and health care issues (e.g., how to avoid malaria and transmission of sexually transmitted infections (STI) HIV/ AIDS);
- train all construction workers in general health and safety matters, and on the specific hazards of their work and all willing personnel on first aid;
- training shall consist of basic hazard awareness, site specific hazards, safe work practices, and emergency procedures for fire, evacuation, and natural disaster, as appropriate;
- commence the malaria, HIV/ AIDS and STI education campaign before the start of the construction phase and complement it with by a strong condom marketing, increased access to condoms in the area as well as to voluntary counseling and testing;
- implement malaria, HIV/ AIDS and STI education campaign targeting all workers hired, international and national, female and male, skilled, semi- and unskilled occupations, at the time of recruitment and thereafter pursued throughout the construction phase on ongoing and regular basis. This shall be complemented by easy access to condoms at the workplace as well as to voluntary counseling and testing.

8. Site Drainage Management

Improper drainage management may result in erosion and siltation, water pondage and resultant health issues.

The Contractor shall

- prepare site drainage plan and get approved by Project Manager prior to construction;
- reinstate damaged drainage lines on priority if the harm is caused by the contractors' vehicles or work practices;
- prepare local drainage line with wide (rather than deep) drains, network of connected cut off drains, new drains, silt collectors, bunds, manholes attended to frequently;
- check the quality of wastewater from the site before being let out into water bodies.

Ponding of Water (*If applicable*)

Health hazards due to mosquito breeding

The Contractor shall

- prevent ponding/ storage of water especially near the waste storage areas and construction camps;
- throw away all the storage containers that may store water after use. Do not store them in upright or open position;
- drain or pump out collected water from clogged rain gutters and ditches;
- properly store any open containers in the work area, such as buckets and cans that are not being used;
- create holes to drain water from containers that cannot be thrown out;
- routinely remove garbage and other debris from drains;
- ensure the topography of the final surface of all raised lands (construction yards, approach roads, access roads, bridge end facilities, etc.) are conducive to enhance natural draining of rainwater/ flood water;
- keep the final or finished surface of all the raised lands free from any kind of depression that insists water logging;
- undertake mitigation measures for erosion control/ prevention by grass-turfing and tree plantation, where there is a possibility of rain-cut that will change the shape of topography;
- Cover immediately the uncovered open surface that has no use of construction activities with grass-cover and tree plantation to prevent soil erosion and bring improved landscaping.

9. Top Soil Management

Disturbance due to Land Clearing and Earth Works

- Topsoil is that uppermost layer of soil capable of growing and supporting vegetation. Topsoil contains the essential microorganisms, nutrients, organic matter, and physical characteristics necessary to grow and sustain permanent vegetation. Stripping, stockpiling, and reusing topsoil on construction projects is essential for proper reclamation of disturbed areas.

The Contractor shall

- strip and store top soil for reusing. Topsoil is recommended on all disturbed sites and slopes 2H:1V or flatter, or as a planting medium for plantings or nursery stock. Topsoil may be added to a rock mulch to enhance slope protection and provide soil medium for seed germination and plant growth. Topsoil can be mixed with organic material such as compost or manufactured soil amendments to improve the growing capability of seeded and planted vegetation;
- strip the top soil to a depth of 15 cm and store in stock piles of height not exceeding 2m;
- limit stockpiling limited to less than 6 months' time so that there is no loss or disruption of microorganisms. The use of microorganism inoculates may be necessary to re-establish microorganisms in topsoil material that has been stockpiled for more than 9 months;

-
- extent practicable, aboveground vegetation, including litter, should be mixed or otherwise incorporated into the topsoil prior to excavation;
 - mix top 1 foot of the stockpile material with the remainder of the stockpile to ensure that living organisms are distributed throughout the topsoil material at the time of final placement, if topsoil is stockpiled prior to placement;
 - not made topsoil stockpiles near/ along drainage lines. It shall be protected from erosion;
 - provide cut-off drains channels and silt bunds around the topsoil stockpiles to prevent erosion of top soil;
 - spread the topsoil to maintain the physico-chemical and biological activity of the soil. The stored top soil will be utilized for covering all disturbed area and along the proposed plantation sites;
 - prior to the re-spreading of topsoil, the rip ground surface to assist the bunding of the soil layers for better water penetration and revegetation;
 - not mix organic material such as wood bark or fiber, grass hay, or grain straw in topsoil unless nitrogen fertilizer is included.

Disturbance due to Vehicular Movement

Vehicular movement outside the right of way of roads or temporary site access roads will disturb top soil and fertility.

The Contractor shall

- mark clearly vehicle access roads and restrict movement to these roads;
- collect and store the topsoil of such accessways for reuse, before initiating movement.

10. Air Quality Management

Construction Vehicular Traffic

Air quality can be adversely affected by vehicle exhaust emissions and combustion of fuels.

The Contractor shall

- Ensure that all vehicles, equipment and machinery to be procured for construction will conform to the relevant Bureau of India Standard (BIS) norms. The discharge standards promulgated under the Environment Protection Act, 1986 and Motor Vehicles Act, 1988 shall be strictly adhered to.
- fit vehicles with appropriate exhaust systems and emission control devices. Maintain these devices in good working condition;
- operate the vehicles in a fuel-efficient manner;
- cover haul vehicles carrying dusty materials moving outside the construction site;
- impose speed limits on all vehicle movement at the worksite to reduce dust emissions;
- control the movement of construction related traffic;
- water construction materials prior to loading and transport;
- service all vehicles regularly to minimize emissions and get PUC certificates on time;

-
- limit the idling time of vehicles not more than 2 minutes.
 - Proper lubrication of vehicles and machinery will be ensured to reduce emissions
 - The Contractor shall maintain a record of PUC for all vehicles and machinery used during the contract period which shall be produced Monitoring agency's verification whenever required.

Construction Machinery

Air quality can be adversely affected by emissions from machinery and combustion of fuels.

The Contractor shall

- fit machinery with appropriate exhaust systems and emission control devices, maintain these devices in good working condition in accordance with the specifications defined by their manufacturers to maximize combustion efficiency and minimize the contaminant emissions. Proof or maintenance register shall be required by the equipment suppliers and contractors/ subcontractors;
- focus special attention on containing the emissions from generators and get permits;
- machinery causing excess pollution (e.g. visible smoke) will be banned from construction sites;
- service all equipment regularly to minimize emissions;
- provide filtering systems, duct collectors or humidification or other techniques (as applicable) to the concrete batching and mixing plant to control the particle emissions in all its stages, including unloading, collection, aggregate handling, cement dumping, circulation of trucks and machinery inside the installations.

Construction Activities

Dust generation from construction sites, material stockpiles and access roads is a nuisance in the environment and can be a health hazard.

- The Contractor shall water the material stockpiles, access roads and bare soils on an as required basis to minimize the potential for environmental nuisance due to dust. Increase the watering frequency during periods of high risk (e.g. high winds). Stored materials such as gravel and sand shall be covered and confined to avoid their being wind-drifted; Water sprinkling shall be done at regular intervals to avoid dust hazards;
- minimize the extent and period of exposure of the bare surfaces;
- reschedule earthwork activities or vegetation clearing activities, where practical, if necessary to avoid during periods of high wind and if visible dust is blowing offsite;
- restore disturbed areas as soon as practicable by vegetation/ grass-turfing;
- store the cement in silos and minimize the emissions from silos by equipping them with filters;
- Store the construction materials in temporarily constructed sheds and covered to avoid dust emissions. Sprinkling of water should be done as and when required to avoid dust from construction activity.
- ensure wet-crushing of rocky and aggregate materials, or performed with particle emission control systems.
- Conduct the soil investigation and submit the report prior to start of construction
- Carry out the demolition and excavation in batches to minimize dust emissions.
- Carry out the diggings, if required for foundation, only in specified area, as per the engineering drawings and excavated earth material should be used for filling and compaction.
- Deposit any chance findings with District Magistrate.
- Provide the protective fencing around the construction sites, excavated areas, and voids. Sign boards should be placed indicating work in progress.
- Take up tree plantation with suitable local species around the periphery of building to enhance the greenery and ambiance
- Permission should be taken from the appropriate authority (State Ground Water Authority) for drilling bore well in notified areas

There should also be a board with contact number in case of any grievances at the site??

11. Noise and Vibration Management

Construction Vehicular Traffic

Noise quality will be deteriorated due to vehicular traffic.

The Contractor shall

-
- maintain all vehicles in order to keep it in good working order in accordance with manufactures maintenance procedures;
 - make sure all drivers will comply with the traffic codes concerning maximum speed limit, driving hours, etc.;
 - organize and schedule the loading and unloading of trucks, and handling operations for the purpose of minimizing construction noise on the work site.

Construction Machinery

Noise and vibration may have an impact on people, property, fauna, livestock and the natural environment.

The Contractor shall

- appropriately site all noise generating activities to avoid noise pollution to local residents;
- inform communities on schedule for high vibration/ noise generating activities;
- use the quietest available plant and equipment;
- place vibrating equipment on absorbent platforms or provide buffers;
- modify equipment to reduce noise (for example, noise control kits, lining of truck trays or pipelines);
- maintain all equipment in order to keep it in good working order in accordance with manufactures maintenance procedures. Equipment suppliers and contractors shall present proof of maintenance register of their equipment;
- install acoustic enclosures around generators to reduce noise levels;
- fit high efficiency mufflers to appropriate construction equipment;
- avoid the unnecessary use of alarms, horns and sirens;
- provide PPE to workers.

Construction Activities

Noise and vibration may have an impact on people, property, fauna, livestock and the natural environment.

The Contractor shall

- notify adjacent landholders prior any typical noise events outside of daylight hours;
- educate the operators of construction equipment on potential noise problems and the techniques to minimize noise emissions;
- employ best available work practices on-site to minimize occupational noise levels;
- install temporary noise control barriers where appropriate;
- notify affected people if major noisy activities will be undertaken, e.g. pile driving;
- plan activities on site and deliveries to and from site to minimize impact;

-
- monitor and analyze noise and vibration results and adjust construction practices as required;
 - avoid undertaking the noisiest activities, where possible, when working at night near the residential areas.

Noise from Diesel Generator Sets

It may be required to use DG sets for various power needs during construction/ other activities under the project. The contractor shall take permissions from the State Pollution Control Board (SPCB) for DG set operations. The following Noise Standards for DG sets are recommended for the running of DG sets during the construction:

- The maximum permissible sound pressure level for new diesel generator sets with rated capacity up to 1000 kVA shall be 75 dB(A) at 1 m from the enclosure surface. Noise from the DG set should be controlled by providing an acoustic enclosure or by treating the enclosure acoustically.
- When required, acoustic enclosure should be made of cold rolled close annealed (CRCA) sheets of appropriate thickness and structural/ sheet metal base. The walls of the enclosure should be insulated with fire retardant foam so as to comply with the 75 dBA at 1m sound levels specified by SPCB.
- The acoustic enclosure/ acoustic treatment of the room should be designed for minimum 25 dB (A) Insertion Loss or for meeting the ambient noise standards, whichever is on the higher side.
- The DG set should also be provided with proper exhaust muffler.
- Proper efforts to be made to bring down the noise levels due to the DG set, outside its premises, within the ambient noise requirements by proper siting and control measures.
- A proper routine and preventive maintenance procedure for the DG set should be set and followed in consultation with the DG set manufacturer which would help prevent noise levels of the DG set from deteriorating with use.

12. Protection of Flora

Vegetation Clearance

Local flora is important to provide shelters for the birds, provide products like fruits and/ or timber/ fire wood, protect soil erosion and overall keep the environment very friendly to human living. As such, damage to flora will result in wide range of adverse environmental impacts.

The Contractor shall

- Avoid the removal of mature trees to the extent possible. If unavoidable, it should be done only after the permissions (as applicable in respective states) from concerned departments. Compensatory tree plantation with same species or suitable local species should be carried out in consultation with Forest Department.
- Transit the timber of important species (as per the applicable state regulations) with permission and support from Forest Department.
- reduce disturbance to surrounding vegetation;
- use appropriate type and minimum size of machine for site clearance to avoid disturbance to adjacent vegetation;

-
- get approval from supervision consultant for clearance of vegetation;
 - make selective and careful pruning of trees where possible to reduce need of tree removal, Control noxious weeds by disposing off at designated dump site;
 - clear only the vegetation that needs to be cleared in accordance with the plans. These measures are applicable to both the construction areas as well as to any associated activities such as sites for stockpiles, disposal of fill and construction of access roads, etc.;
 - do not burn off cleared vegetation; rather chip or mulch and reuse it for the rehabilitation of affected areas, temporary access tracks or landscaping. Mulch provides a seed source, can limit embankment erosion, retains soil moisture and nutrients, and encourages regrowth and protection from weeds. It can also be composted as used as a good manure for landscaping works on site using bin composting;
 - return topsoil and mulched vegetation (in areas of native vegetation) to approximately the same area it came from;
 - avoid work within the drip-line of trees to prevent damage to the tree roots and compacting the soil;
 - minimize the length of time the ground is exposed or excavation left open by clearing and re-vegetate the area at the earliest practically possible;
 - ensure excavation works occur progressively and revegetation done at the earliest;
 - provide adequate knowledge to the workers regarding nature protection and the need to avoid felling trees during construction;
 - follow national (or state) guidelines on replantation if this is suggested;
 - use indigenous plants and trees for landscaping the site or compensatory afforestation in consultation with local community, Forest Department and local authorities;
 - supply appropriate fuel for labour camps to prevent fuel wood collection;
 - use sheets or other lightweight cloth to cover plants and at the same time allow some light and air to enter during construction near existing plants and trees, In the case of delicate plants, make a scaffold around the specimen to prevent the cloth from crushing foliage and stems;
 - prevent any spills or hazardous chemicals, paints or tools from harming the plants and trees;
 - prevent the release of any materials or wastes into waterbodies which would cause eutrophication or harm the aquatic species.

13. Protection of Fauna

Construction Activities

The location of construction activities can result in the loss of wild life habitat and habitat quality.

The Contractor shall

- limit the construction works within the designated sites allocated to the contractors, and no activity shall spill over;

-
- limit work activities to day time; avoid nesting/ breeding time for work while scheduling the work;
 - check the site for animals trapped in, or in danger from site works and use a qualified person to relocate the animal.

Impact on Migratory Birds, Its Habitat and Its Active Nests

The Contractor shall

- not destruct active nests or eggs of migratory birds;
- minimize the tree removal during the bird breeding season. If works must be continued during the bird breeding season, a nest survey will be conducted by a qualified biologist prior to commence of works to identify and locate active nests;
- minimize the release of oil, oil wastes or any other substances harmful to migratory birds to any waters or any areas frequented by migratory birds;
- control light pollution of nesting/ breeding areas and flight pathways of birds;
- prevent the release of any materials (including plastics, construction materials) or wastes (solid/ liquid from works or camps) into waterbodies which would cause eutrophication or harm the aquatic species;
- prevent sediments from flowing into waterbodies harming the biota.
 - Sediment may be washed into streams from construction works sites. It causes the water to turn turbid ("murky") and reduces light penetration;
 - Construction near streams must be carefully undertaken by a skilled professionals to limit sedimentation. Interceptor ditches, sediment fencing and sediment control ponds are some methods that can limit sediment that flows into waterways.
 - Cover exposed earth with a tarpaulin or geomembranes if rain is expected. Replant exposed areas with grass seed or other fast-growing plants as soon as possible.

Vegetation Clearance

Clearance of vegetation may impact shelter, feeding and/ or breeding and/ or physical destruction and severing of habitat areas

The Contractor shall

- restrict the tree removal to the minimum required; take necessary permissions where required for removal and transit
- retain tree hollows on site, or relocate hollows, where appropriate;
- leave dead trees where possible as habitat for fauna;
- fell the hollow bearing trees in a manner which reduces the potential for fauna mortality;
- felled trees will be inspected after felling for fauna and if identified and readily accessible will be removed and relocated or rendered assistance if injured. After felling, hollow bearing trees will remain unmoved overnight to allow animals to move of their own volition.

-
- Logging of felled trees will be made as appropriate.

Construction Camps: Illegal Poaching

The Contractor shall

- provide adequate knowledge to the workers regarding protection of flora and fauna, and relevant government regulations and punishments for illegal poaching.

14. Road Transport and Road Traffic Management

Construction Vehicular Traffic

Increased traffic use of road by construction vehicles will affect the movement of normal road traffics and the safety of the road-users.

The Contractor shall

- prepare and submit a traffic management plan to the Project Manager for his approval at least 30 days before commencing work on any project component involved in traffic diversion and management. This shall be presented to Traffic Police Department and other line departments and permissions gathered before start of works;
- include the traffic management plan to ensure uninterrupted traffic movement during construction: detailed drawings of traffic arrangements showing all detours, temporary road, temporary bridges, temporary diversions, necessary barricades, warning signs/ lights, and road signs;
- provide signs at strategic locations of the roads complying with the schedules of signs contained in the Traffic Regulations. Arrange flagmen if required especially near sensitive receptors such as schools, hospitals, commercial areas;
- install and maintain a display board at each important road intersection on the roads to be used during construction, which shall clearly show the following information in local language:
 - Location:
 - Locality name:
 - Duration of construction period:
 - Period of proposed detour/ alternative route:
 - Suggested detour route map:
 - Name and contact address/ telephone number of the concerned personnel:
 - Name and contact address/ telephone number of the Contractor:
 - Following written “ Inconvenience is sincerely regretted”.

Accidents and Spillage of Fuels and Chemicals

The Contractor shall

- restrict truck deliveries, where practicable, to day time working hours;
- restrict the transport of oversize loads;

-
- operate road traffics/ transport vehicles, if possible, to nonpeak periods to minimize traffic disruptions;
 - enforce on-site speed limit.

15. Cultural and Religious Issues

Construction Activities near Religious and Cultural Sites

Disturbance from construction works to the cultural and religious sites, and contractors lack of knowledge on cultural issues cause social disturbances.

The Contractor shall

- communicate to the public through community consultation, informing the peers and newspaper announcements regarding the scope and schedule of construction, as well as certain construction activities causing disruptions or access restriction;
- not block access to cultural and religious sites and sites of importance for livelihood activities, wherever possible;
- restrict all construction activities within the foot prints of the construction sites;
- stop construction works that produce noise (particularly during prayer time) shall there be any mosque/ religious/ educational institutions close to the construction sites and users make objections;
- take special care and use appropriate equipment when working next to a cultural/ religious institution;
- stop work immediately and notify the Project Manager if, during construction, an archaeological or burial site is discovered. It is an offence to recommence work in the vicinity of the site until approval to continue is given by the Project Manager;
- provide separate prayer facilities to the construction workers;
- show appropriate behaviour with all construction workers and community especially women and elderly people;
- monitor and be responsible for the behaviours of construction workers especially migrant workers towards the community and environment and take actions to stop their services after warning in case found necessary. The workers must be debriefed well regarding local aspects and need to follow good behaviours, and informed regarding unexpected behaviours at the time of employing;
- allow the workers to participate in prayers during construction time;
- resolve cultural issues in consultation with local leaders and Project Manager;
- establish a mechanism that allows local people to raise grievances (directly and indirectly) arising from the construction process;

inform the local authorities responsible for health, religious and security duly informed before commencement of civil works so as to maintain effective surveillance over public health, social and security matters.

16. Management of Asbestos-containing Material:

Asbestos-containing Material (ACM) should be avoided in new buildings or as new material in remodelling or renovation

- **Existing buildings:** ACM Survey and management plan needed
- **Disposal of ACM** shall be carried out by specially trained individuals only following the government rules and regulations.

The contractor shall

- Assess risk to determine extent of problem;
- survey to abate asbestos exposure;
- prepare management plan;
- remove ACM by trained personnel;
- follow prohibition of ACM;
- prepare procedures for handling, removal, transport, and disposal of asbestos.

Annexure To ESHS Guidelines

‘To Do’ Protocols/Guidance for Construction Sites and Construction Workers in response to COVID-19

In view of COVID-19 outbreak, various guidelines / interim notes for construction sites have been prepared by institutions and organizations, e.g. The World Bank (April 7, 2020), ILO (March 19, 2020), IASC (March 17, 2020), besides by WHO from time to time.

All the Governments in SAR countries would have issued guidelines to combat COVID-19 spread. In case of India, for example, the Ministry of Home Affairs and Ministry of Health and Family Welfare, issued several Orders/Circulars/Guidelines³² from time to time to be followed by the State governments, sectors and individuals. Further, amendments to these orders are updated from time to time on <https://www.mha.gov.in/media/whats-new>,

The national orders/circulars/guidelines are required to be followed in all operations. In addition, various guidelines / interim notes for construction sites have been prepared by several institutions and organizations, some of which are listed below:

³² <https://www.mha.gov.in/notifications/circulars-covid-19>,
https://www.mha.gov.in/sites/default/files/PR_ConsolidatedGuidelinesofMHA_28032020_0.pdf,
<https://www.mohfw.gov.in/>

-
- a. ILO's Guidance: Considerations for employment intensive works in response to COVID 19 (April 12, 2020). https://www.ilo.org/wcmsp5/groups/public/---ed_emp/documents/publication/wcms_741669.pdf
 - b. WB's ESF/Safeguards interim note: COVID-19 considerations in construction/civil works projects (April 7, 2020).
 - c. WHO's guidelines: Getting your workplace ready for COVID-19 (March 03, 2020) <https://www.who.int/docs/default-source/coronaviruse/getting-workplace-ready-for-covid-19.pdf>; Water, sanitation, hygiene, and waste management for the COVID-19 virus (March 19, 2020) <https://www.who.int/publications-detail/water-sanitation-hygiene-and-waste-management-for-covid-19>; Rational use of personal protective equipment (PPE) for coronavirus disease (March 19, 2020): https://apps.who.int/iris/bitstream/handle/10665/331695/WHO-2019-nCov-IPC_PPE_use-2020.3-eng.pdf.
 - d. IASC Interim Guidance: Scaling-Up Covid-19 Outbreak Readiness and Response Operations in Humanitarian Situations, Including Camps and Camp-Like Settings (March 17, 2020) <https://interagencystandingcommittee.org/other/interim-guidance-scaling-covid-19-outbreak-readiness-and-response-operations-camps-and-camp>
 - e. IDB's Guidance for infrastructure projects on COVID-19 <https://www.idbinvest.org/en/download/9625>
 - f. IFC Guidance: Workers' accommodation: processes and standards (2009) <http://documents.worldbank.org/curated/en/604561468170043490/pdf/602530WP0worke10Box358316B01PUBLIC1.pdf>

Labor would continue to be the major player in construction activities in coming time. In view of the prevailing COVID-19 pandemic, the contractors and workers would need to take additional measure to avoid the spread of the disease or risk of infection. On the basis of above guidelines/guidance notes, a brief "To Do" list is summarized below (reference numbers in brackets refer to the above-mentioned guidelines/guidance notes). For details and preparation of COVID Response and Management Plan, the above documents may be referred.

'To Do' List / Protocol

SAFETY OF WORKERS - DAILY DRILL:

- 1) The work timings should be phased for each shift. *There should be a difference of about 1 hour between two shifts* and the sensitive areas of the workplace should be cleaned/sanitized by a defined set of specifically equipped workers. (Ref: b)
- 2) The time between two shifts should be used for cleaning and sanitizing machines, hand tools and areas of regular contact – grab handles, control levers, steering wheels, control panels, etc. shall be regularly cleaned, and at the end of shifts used across shifts (or continuous operations) where operators/helpers change. (Ref: a)
- 3) All workers to report some time earlier before the start of the shift. An attendance register is to be maintained for each shift. Masks are mandatory and social distancing of at least 1m to be followed in the holding area prior to entry into the worksite. The EHS Focal Point to provide information update every day. (Ref: a, c, d)
- 4) The workers need to wash their hands thoroughly (for at least 20-30 seconds) with soap or use sanitizers just before reporting for screening. Adequate provision for hand washing, soaps, sanitizers, water collection and disposal of sullied water needs to be made at the entry of the reporting location. Hand gloves mandatory for teams who are screening workmen, conducting medical checkup, disinfection. (Ref: a, b, c)
- 5) Health screening to be done for all workers in the shift to enter the workplace/worksite - including temperature monitoring using a non-contact thermometer. Any worker reporting with temperature higher than 37.3°C shall be sent to the isolation quarters and periodic observation be made. (Ref: a, b, c, d)
 - i) In case the worker shows symptoms of any disease/ailment (including COVID-19), the procedures as laid down by the national and state laws need to be followed for testing, quarantine of at least 14 days or hospitalization, depending upon individual case.
 - ii) All the co-workers in the shift, and other persons with known contact history in the construction site should be quarantined for a period of at least 14 days, followed by regular checkups/ observation/ examinations as laid down by the national and state laws.
- 6) The workers found fit need to proceed to work with all required personal protective equipment, e.g. masks, gloves, goggles, boots, helmets, harness, etc. (Ref: a, b, c)
- 7) The workers be encouraged to avoid contact with co-workers as far as possible and wash their hands at regular intervals. (Ref: a, b, c)
- 8) Lunch/meal break be staggered into two or more time slots so that workers proceed for lunch/meal at different times (Ref: a).

-
- 9) There needs to be a provision of separate drinking bottles/cups for each worker, and these need to be cleaned thoroughly after meals. (Ref: a)
 - 10) Proper hand washing arrangement (water/soaps/sanitizers) needs to be ensured at eating locations. Hand washing facilities are ideally to be located within 5m of toilets and at close range of eating space. (Ref: a, b)
 - 11) The workers returning to the shift after lunch/meal break need to thoroughly wash their hands and follow the same procedure as that followed at the start of the shift. (Ref: a, b)
 - 12) At the close of shift, the workers need to thoroughly wash their hands with soap/sanitizers prior to leaving the workplace/worksite. (Ref: a, b)
 - 13) The PPE should be thoroughly washed/cleaned/sanitized (depending upon the type of PPE) after the shift ends. (Ref: a)

OTHER GUIDANCE FOR CONTRACTORS:

- 1) Site specific risk assessment needs to be undertaken and emergency preparedness plan be prepared for all sites, including camp sites and construction sites. (Ref: a, b, d, e)
- 2) Protocols for medical treatment, etc. should be prepared/followed, including for reporting, referral, treatment and discharge as per national and state laws and other guidelines. (Ref: a, b, c, d)
- 3) A health and safety officer to be deployed as the focal point at all project sites, and wherever, the same (or the Environment, health and Safety Officer) is not in place, urgent action needs to be taken by the contractor to recruit and mobilize someone with appropriate qualifications and responsibilities. (Ref: a, b)
- 4) Register for all the workers needs to be maintained, along with their health records. Prepare a profile of the workforce considering the following: (i) total number of workers who live in the labor camps; (ii) total number of workers who commute from their houses; and (iii) number of male and female workers. (Ref: a, b, d).
- 5) Limit the number of workers on site at any one time to minimize contact, including exploring operations for multi-shift working rotation. (Ref: a, b, d)
- 6) Entry/exit to the site should be documented. Transport vehicles used during construction activities to carry construction materials should be sanitized on regular basis (at least once a day). (Ref: a, b)
- 7) Hygienic living conditions need to be ensured in the camp sites with regular/daily cleaning, adequate handwashing facilities. Adequate provision for solid waste management needs to be provided. (Ref: a, b, d, f)
- 8) Provide health and safety training/orientation on COVID19, or any other pandemic, to all workers and staff. Initiatives could include training family members of construction workers to stitch masks and gloves to augment PPE. (Ref: a, b, d)

-
- 9) Ensure adequacy of necessary supplies of energy, water, food, medical supplies, cleaning equipment, PPE (both for regular use and those for medical exigencies) etc. (Ref: a, b, c, d, f)
 - 10) Quarantine and isolation facilities should be established in the camps (as per the WHO Guidelines). The isolation facilities should have separate and dedicated toilets with proper arrangement for cleaning and removal of sewage and wastes. (Ref: c)
 - 11) Any medical waste produced during the care of ill workers should be disposed as per the national and state laws or relevant guidelines (e.g. WHO guidelines issued from time to time). (Ref: a, b, c)
 - a) PPE used for medical treatment/care purposes should be stored securely and kept separate from other waste. (Ref: a, b, c)
 - b) Current WHO recommendations are to clean utility gloves or heavy duty, reusable plastic aprons with soap and water and then decontaminate them with 0.5% sodium hypochlorite solution after each use. (Ref: a, b, c)
 - c) Single-use gloves (nitrile or latex) and gowns should be discarded after each use and not reused. (Ref: a, b, c)
 - 12) Incentivize workers lodging in the local community to move to site accommodation. (Ref: b)
 - 13) The community should be made aware, through posters etc., of procedures put in place at site to address issues related to COVID-19. This should include all measures being implemented to limit or prohibit contact between workers and the community. (Ref: a, b, c, d)

ADDITIONAL GUIDANCE FOR GOOD PRACTICE FOR CONTRACTORS:

- 1) Follow national orders/circulars/guidelines issued from time to time
- 2) Apply the guidelines/guidance notes referred in the documents (a to f)
- 3) Practice the Daily Drill and General Guidance above.
- 4) Camp sites and construction sites may require different approaches to avoid spread of COVID-19. Special care to be taken for supply chain related vehicles, personnel and material.

Provide Contactless attendance system

Appendix -3³⁶

Appointment of Adjudicator / Dispute Review Expert

Suggested Draft of Letter of Appointment of Adjudicators in civil works contracts

Sub: _____ (Name of the Contract)

To

Name and address of the Adjudicator / Dispute Review Expert

We hereby confirm your appointment as Adjudicator/ Dispute Review Expert for the above contract to carry out the assignment specified in this Letter of Appointment.

For administrative purpose _____ (*name of the officer representing the Employer*) has been assigned to administer the assignment and to provide the Adjudicator / Dispute Review Expert with all relevant information needed to carry out the assignment on behalf of both the Employer and the contractor. The services will be required during the period of contract for the work of (Name of the Contract) _____.

The Adjudicator / Dispute Review Expert shall visit the worksite once in 3 (three) months till the completion of the work indicated above or as specifically requested by Employer/ Contractor for the period upto the end of defects liability period with prior intimation to the Employer and the contractor. The duration of each visit shall ordinarily be for one day only. These durations are approximate and (*Name of the Employer and Name of the Contractor*) may find it necessary to postpone or cancel the assignment and/or shorten or extend the duration.

The appointment will become effective upon confirmation of letter by you. The appointment of Adjudicator/ Dispute Review Expert shall be liable for termination under a 30 (thirty) days written notice from the date of issue of the notice, if both Employer and the Contractor so desire. Also the appointment shall automatically stand terminated 14 days after the defect notice / correction period as stated in Clauses 23 and 24 of the Conditions of Contract is over.

The Adjudicator/ Dispute Review Expert will be paid a fee of Rs. _____ (Rupees _____ only) per each day of visit at the worksite. The actual expenses for boarding and traveling in connection with the assignment will be reimbursed to the Adjudicator/ Dispute Review Expert. The Adjudicator/ Dispute Review Expert will submit a pre-receipted bill in triplicate to the Employer indicating the date of the visit, fees for the visit and a proof in support of the actual expenditure [only for items valued above Rs. 200 each] incurred by him against boarding, lodging and traveling expenses after performing the visit on each occasion. The Employer will make the admissible payment (both the Employer's and the Contractor's share) to the Adjudicator/ Dispute Review Expert within 30 days of the receipt of the bill. The Contractor's share on this

³⁶ If ITB 43 makes provision of an Adjudicator from list provided by an institution, kindly modify Appendix 3 to state that the fee and reimbursable payable to the adjudicator shall be as per the rules of the Institution.

account(half the paid amount) will be recovered by the Employer from the Contractor's bills against the work.

In accepting this assignment, the Adjudicator/ Dispute Review Expert should understand and agree that he is responsible for any liabilities and costs arising out of risks associated with travel to and from the place of emergency repatriation, loss or damage to personal/professional effects and property. The Adjudicator/ Dispute Review Expert is advised to effect personal insurance cover in respect of such risks if he does not already have such cover in place. In this regard, the Adjudicator/ Dispute Review Expert shall maintain appropriate medical, travel, accident and third-party liability insurance. The obligation under this paragraph will survive till termination of this appointment.

Procedures for resolution of disputes by the Adjudicator/ Dispute Review Expert is described in the contract of _____(name of the contract) between the Employer and the contractor vide clause no.24 of the General Conditions of Contract. Your recommendation should be given in the format attached, within 28 days of receipt of a notification of dispute.

The Adjudicator/ Dispute Review Expert will carry out the assignment in accordance with the highest standard of professional and ethical competence and integrity, having due regard to the nature and purpose of the assignment, and will conduct himself in a manner consistent herewith. After visiting the worksite, the Adjudicator / Dispute Review Expert will discuss the matter with the Employer and if necessary with the Contractor before arriving at any decision.

The Adjudicator/ Dispute Review Expert will agree that all knowledge and information not within the public domain, which may be acquired while carrying out this service shall be all time and for all purpose, regarded as strictly confidential and held in confidence, and shall not be directly or indirectly disclosed to any party whatsoever, except with the permission of the Employer and the contractor. The Adjudicator's decision should be communicated in the form of a speaking order specifying the reasons.

The Adjudicator/ Dispute Review Expert will agree that any manufacturing or construction firm with which he might be associated with, will not be eligible to participate in bidding for any goods or works resulting from or associated with the project of which this consulting assignment forms a part

Read and Agreed

Name of Adjudicator/ Dispute Review Expert
Signature

Place:

Date:

Name of Employer

Signature of authorized representative of Employer

Name of the Contractor

Signature of authorized representative of Contractor

Attachment: Copy of contract document between the Employer and contractor and format for recommendation.

SUMMARY OF ADJUDICATOR'S RESPONSIBILITIES

The Adjudicator has the following principal responsibilities:

1. Visit the site periodically.
2. Keep abreast of job activities and developments.
3. Encourage the resolution of disputes by the parties.
4. When a dispute is referred to it, conduct a hearing (no legal presentation), complete its deliberations, and prepare a recommendations in a professional and timely manner(as per sample format)

[IN THIS AND THE NEXT FORM, USE THE TERM ADJUDICATOR, OR DISPUTE REVIEW EXPERT AS SPECIFIED IN THE REST OF THE BIDDING DOCUMENT.]

Sample Format of Adjudicator's Recommendation

[Project Name] Recommendation of Adjudicator

Dispute No. XX [NAME OF DISPUTE]

Hearing Date: _____

Dispute

Description of dispute. A one or two sentence summation of the dispute.

Contractor's Position

A short summation of the contractor's position as understood by the Adjudicator.

Employer's Position

A short summation of the Employer's position as understood by the Adjudicator.

Recommendation

The Adjudicator's specific recommendation for settlement of the dispute. (*The recommended course is consistent with the explanation*).

Explanation

(*This section could also be called Considerations, Rationale, Findings, Discussion, and so on.*)

The Adjudicator's description of how each recommendation was reached.

Respectfully submitted,

Date : _____

Date : _____

Date : _____

Section X - Contract Forms

This Section contains forms which, once completed, will form part of the Contract. The forms for Performance Security and Advance Payment Security, when required, shall only be completed by the successful Bidder after contract award.

Letter of Acceptance

[letterhead paper of the Employer]

[The Letter of Acceptance shall be the basis for formation of the Contract as described in ITB Clause 43. This Standard Form of Letter of Acceptance shall be filled in and sent to the successful Bidder only after evaluation of bids has been completed, subject to any review by the World Bank required under the Loan Agreement.]

[insert date]

Identification No and Title of Contract: *[insert identification number and title of the Contract]*

To: *[insert name and address of the Contractor]*

This is to notify you that your Bid dated *[insert date]* for execution of the *[insert name of the Contract and identification number, as given in the PCC]* for the Contract Price *[insert amount in numbers and words]* as corrected and modified³⁷ in accordance with the Instructions to Bidders is hereby accepted by our Agency.

[insert one of the following (a) or (b) options]

- (a) We accept that *[insert name proposed by bidder]* be appointed as the Adjudicator/Dispute Review Expert [DRE].³⁸
- (b) We do not accept that *[insert name proposed by bidder]* be appointed as Adjudicator/DRE, and by sending a copy of this Letter of Acceptance to *[insert name of the Appointing Authority]*, we are hereby requesting *[insert name]*, the Appointing Authority, to appoint the Adjudicator/DRE in accordance with GCC 23.³⁹

We note that as per your bid, you do not intend to subcontract any component of work.

[OR]

We note that as per your bid, you propose to employ M/s. as sub-contractor for executing

³⁷ Delete "corrected and" or "and modified" if not applicable. See Notes on Standard Form of Agreement, next page.

³⁸ To be used only if the Contractor disagrees in the Bid with the Adjudicator proposed by the Employer in the Instructions to Bidders, and has accordingly offered another candidate.

³⁹ To be used only if the Contractor disagrees in the Bid with the Adjudicator proposed by the Employer in the ITB, has accordingly offered another candidate, and the Employer does not accept the counterproposal.

[Delete whatever is inapplicable]

You are hereby requested to furnish Performance Security, plus additional security for unbalanced bids in terms of ITB clause 40, in the form detailed in ITB Clause 45 for amounts⁴⁰ of Rs. ____ and Rs _____ specified therein, within 21 days of the receipt of this letter of acceptance, and visit this office to sign the contract, failing which action as stated in ITB Clause 45.2 will be taken. The securities shall be valid up to 28 days from the date of completion i.e. up to and shall be as per the Performance Security Form and the ESHS Performance Security Form, included in Section X - Contract Forms, of the bidding document.

We have reviewed the construction methodology submitted by you along with the bid in response to ITB Clause 16 and our comments are given in the attachment. You are requested to submit a revised Program including environmental management plan as per Clause 26 of General Conditions of Contract within 14 days of receipt of this letter of acceptance.

Yours faithfully,

Authorized Signature.....

Name and Title of Signatory.....

Name of Agency.....

⁴⁰*Insert amounts for (i) Performance Security, plus additional security for unbalanced bids; and (ii) ESHS Performance Security respectively.*

Issue of Notice to proceed with the work

(letterhead of the Employer)

_____ (date)

To

_____ (name and address of the Contractor)

Dear Sirs:

Pursuant to your furnishing the requisite securities as stipulated in ITB clause 45.1, insurance policy as per GCC 13, construction methodology as stated in letter of acceptance and signing of the contract agreement for the construction of _____ @ a Bid Price of Rs. _____, you are hereby instructed to proceed with the execution of the said works in accordance with the contract documents.

Yours faithfully,

(Signature, name and title of
signatory authorized to sign on
behalf of Employer)

Attachment: Contract Agreement

Contract Agreement

THIS AGREEMENT made theday of,, between
[name of the Employer]. (hereinafter “the Employer”), of the one part, and
[name of the Contractor].(hereinafter “the Contractor”), of the other part:

WHEREAS the Employer desires that the Works known as[name of the Contract].
should be executed by the Contractor, and has accepted a Bid by the Contractor for the execution and completion of these Works and the remedying of any defects therein,

The Employer and the Contractor agree as follows:

1. In this Agreement words and expressions shall have the same meanings as are respectively assigned to them in the Contract documents referred to.
2. The following documents shall be deemed to form and be read and construed as part of this Agreement. This Agreement shall prevail over all other Contract documents.
 - (a) this Agreement
 - (b) the Letter of Acceptance
 - (c) the Contractor’s Bid including completed schedules and priced bill of quantities,
 - (d) the Addenda No’s [insert addenda numbers if any].
 - (e) the Particular Conditions of contract
 - (f) the General Conditions of contract;
 - (g) the Specifications
 - (h) the Drawings; and
 - (i) Construction Program, Methodology, Quality Assurance Program and Environmental Management Plan
 - (j) Joint Venture Agreement [for JVs only]
 - (k) Any other document listed in PCC as forming part of the Contract
3. In consideration of the payments to be made by the Employer to the Contractor as indicated in this Agreement, the Contractor hereby covenants with the Employer to execute the Works and to remedy defects therein in conformity in all respects with the provisions of the Contract.
4. The Employer hereby covenants to pay the Contractor in consideration of the execution and completion of the Works and the remedying of defects therein, the Contract Price or such other sum as may become payable under the provisions of the Contract at the times and in the manner prescribed by the Contract.

IN WITNESS whereof the parties hereto have caused this Agreement to be executed in accordance with the laws of *[name of the borrowing country]*. . . . on the day, month and year indicated above.

Signed by: _____ Signed by: _____
for and on behalf of the Employer for and on behalf of the Contractor
in the presence of: _____ in the presence of: _____
in the presence of: _____
Witness, Name, Signature, Address, Date
Witness, Name, Signature, Address, Date

Performance Security - Bank Guarantee

[including Additional Performance Security for unbalanced bids]

[Guarantor letterhead or SWIFT identifier code]

Performance Guarantee No.....*[insert guarantee reference number]*

Date.....*[insert date of issue of the guarantee]*

To: _____ *[name of Employer]*
_____ *[address of Employer]*

WHEREAS _____ *[name and address of Contractor⁴¹]*
(hereinafter called "the Contractor") has undertaken, in pursuance of Contract No. _____
dated _____ to execute _____ *[name of Contract*
and brief description of Works] (hereinafter called "the Contract");

AND WHEREAS it has been stipulated by you in the said Contract that the Contractor shall furnish you with a Bank Guarantee by a recognized bank for the sum specified therein as security for compliance with his obligations in accordance with the Contract;

AND WHEREAS we have agreed to give the Contractor such a Bank Guarantee;

NOW THEREFORE we hereby affirm that we are the Guarantor and responsible to you, on behalf of the Contractor, up to a total of _____ *[amount of guarantee⁴²]* _____ *[in words]*, such sum being payable in the types and proportions of currencies in which the Contract Price is payable, and we undertake to pay you, upon your first written demand and without cavil or argument, any sum or sums within the limits of _____ *[amount of guarantee]* as aforesaid without your needing to prove or to show grounds or reasons for your demand for the sum specified therein.

We hereby waive the necessity of your demanding the said debt from the Contractor before presenting us with the demand.

We further agree that no change or addition to or other modification of the terms of the Contract or of the Works to be performed thereunder or of any of the Contract documents which may be made between you and the Contractor shall in any way release us from any liability under this guarantee, and we hereby waive notice of any such change, addition or modification.

⁴¹*In the case of a JV, insert the name of the Joint Venture*

⁴²*An amount shall be inserted by the Guarantor, representing the percentage of the Contract Price specified in the Contract less provisional sum if any, plus additional performance security for unbalanced bids if any, and denominated in Indian Rupees.*

This guarantee shall be valid until (i.e.) 28 days from the date of expiry of the Defects Liability Period, and any demand for payment under it must be received by us at this office on or before that date.

Signature and seal of the guarantor _____

Name of Bank _____

Address _____

Date _____

Note: All italicized text (including footnotes) is for use in preparing this form and shall be deleted from the final product.

**Environmental, Social, Health and Safety (ESHS)
Performance Security - Bank Guarantee**
[Guarantor letterhead or SWIFT identifier code]

ESHS Performance Guarantee No.....*[insert guarantee reference number]*
Date.....*[insert date of issue of the guarantee]*

To: _____ *[name of Employer]*
_____ *[address of Employer]*

WHEREAS _____ *[name and address of Contractor⁴³]*
(hereinafter called "the Contractor") has undertaken, in pursuance of Contract No. _____
dated _____ to execute _____ *[name of Contract
and brief description of Works]* (hereinafter called "the Contract");

AND WHEREAS it has been stipulated by you in the said Contract that the Contractor shall furnish you with a Bank Guarantee by a recognized bank for the sum specified therein as security for compliance with Environmental, Social, Health and/or Safety (ESHS) obligations in accordance with the Contract;

AND WHEREAS we have agreed to give the Contractor such a Bank Guarantee;

NOW THEREFORE we hereby affirm that we are the Guarantor and responsible to you, on behalf of the Contractor, up to a total of _____ *[amount of guarantee⁴⁴]* _____ *[in words]*, such sum being payable in the types and proportions of currencies in which the Contract Price is payable, and we undertake to pay you, upon your first written demand and without cavil or argument, any sum or sums within the limits of _____ *[amount of guarantee]* as aforesaid without your needing to prove or to show grounds or reasons for your demand for the sum specified therein.

We hereby waive the necessity of your demanding the said debt from the Contractor before presenting us with the demand.

We further agree that no change or addition to or other modification of the terms of the Contract or of the Works to be performed thereunder or of any of the Contract documents which may be made between you and the Contractor shall in any way release us from any liability under this guarantee, and we hereby waive notice of any such change, addition or modification.

This guarantee shall be valid until (i.e.) 28 days from the date of expiry of the Defects Liability Period, and any demand for payment under it must be received by us at this office on or before that date.

⁴³*In the case of a JV, insert the name of the Joint Venture*

⁴⁴*An amount shall be inserted by the Guarantor, representing the percentage of the Contract Price specified in the Contract less provisional sum if any, and denominated in Indian Rupees.*

Signature and seal of the guarantor _____

Name of Bank _____

Address _____

Date _____

Note: All italicized text (including footnotes) is for use in preparing this form and shall be deleted from the final product.

Advance Payment Security

Demand Guarantee

[Guarantor letterhead or SWIFT identifier code]

Advance Payment Guarantee No.....*[insert guarantee reference number]*

Date.....*[insert date of issue of the guarantee]*

To: _____ *[name of Employer]*
_____ *[address of Employer]*
_____ *[name of Contract]*

Gentlemen:

In accordance with the provisions of the Conditions of Contract, Sub-clause 49.1 ("Advance Payment") of the above-mentioned Contract, _____ *[name and address of Contractor⁴⁵]* (hereinafter called "the Contractor") shall deposit with _____ *[name of Employer]* a bank guarantee to guarantee his proper and faithful performance under the said Clause of the Contract in an amount of _____ *[amount of guarantee⁴⁶]* _____ *[in words]*.

We, the _____ *[bank or financial institution]*, as instructed by the Contractor, agree unconditionally and irrevocably to guarantee as primary obligator and not as Surety merely, the payment to _____ *[name of Employer]* on his first demand without whatsoever right of objection on our part and without his first claim to the Contractor, in the amount not exceeding _____ *[amount of guarantee]* _____ *[in words]*.

We further agree that no change or addition to or other modification of the terms of the Contract or of Works to be performed thereunder or of any of the Contract documents which may be made between _____ *[name of Employer]* and the Contractor, shall in any way release us from any liability under this guarantee, and we hereby waive notice of any such change, addition or modification.

This guarantee shall remain valid and in full effect from the date of the advance payment under the Contract until _____ *[name of Employer]* receives full repayment of the same amount from the Contractor. Consequently any demand for payment under this guarantee must be received by us at this office on or before that date.

Yours truly,

⁴⁵In the case of a JV, insert the name of the Joint Venture

⁴⁶An amount shall be inserted by the bank representing the amount of the Advance Payment, and denominated in Indian Rupees.

Signature and seal:

Name of Bank: _____

Address:

Date: _____

Note: All italicized text(including footnotes) is for use in preparing this form and shall be deleted from the final product.

Retention Money Security

Demand Guarantee

[Guarantor letterhead or SWIFT identifier code]

_____ *[Bank's name and address of issuing branch or office]*

Beneficiary: _____ *[Name and Address of Employer]*

Date: _____

RETENTION MONEY GUARANTEE NO.: _____

We have been informed that _____ *[name of contractor⁴⁷]* (hereinafter called "the Contractor") has entered into Contract No. _____ *[reference number of the contract]* dated _____ with you, for the execution of _____ *[name of contract and brief description of Works]* (hereinafter called "the Contract").

Furthermore, we understand that, according to the conditions of the Contract, when the Taking-Over Certificate has been issued for the Works and the first half of the Retention Money has been certified for payment, payment of _____ *[insert the second half of the Retention Money]* is to be made against a Retention Money guarantee.

At the request of the contractor, we _____ *[name of Bank]* hereby irrevocably undertake to pay you the sum or sums not exceeding in total an amount of _____ *[amount in Rupees]* (_____ *[amount in words⁴⁸]*) upon receipt by us of your first demand in writing accompanied by a written statement stating that the Contractor is in breach of its obligation under the Contract without cavil or argument.

It is a condition for any claim and payment under this guarantee to be made that the payment of the second half of the Retention Money referred to above must have been received by the Contractor on its account number _____ at _____ *[name and address of Bank]*.

This guarantee shall expire, at the latest, 21 days after the date when the Employer has received a copy of the Defects Liability Certificate issued by the Project Manager. Consequently, any demand for payment under this guarantee must be received by us at this office on or before that date.

[Signature(s) and seal of the guarantor]

Note: All italicized text (including footnotes) is for use in preparing this form and shall be deleted from the final product.

⁴⁷*In the case of a JV, insert the name of the Joint Venture*

⁴⁸*The Guarantor shall insert an amount representing the amount of the second half of the Retention Money.*